

atg airports ltd

illuminated Airfield Signs



Sign Installation, Commissioning and Maintenance Manual

HZ31-0-01 Issue 8

IR858

Single Sided LED Airfield Guidance Signs

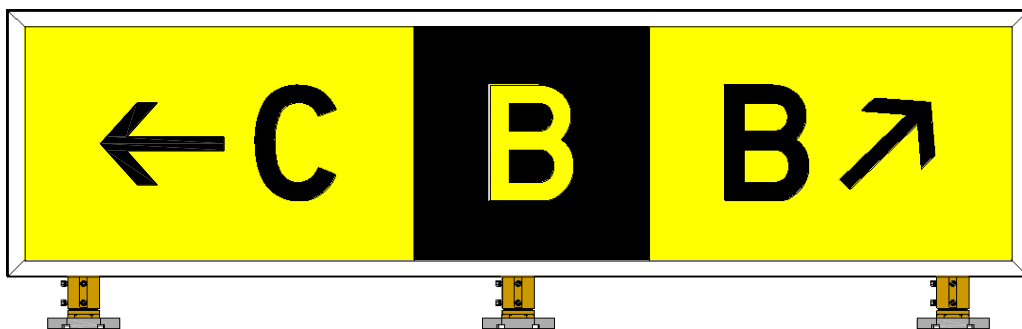

SAFETY WARNING

This document should be read carefully before commencing installation or maintenance on any atg airports signs

The signs are manufactured to operate from a mains supply voltage or a Constant Current AGL series circuit with a secondary current of 6.6 amps. In either case dangerous voltages are present and any work carried out on the signs or their power supplies must be carried out in accordance with the following information.

STATUTORY REGULATIONS AND CODES OF PRACTICE

Regulations, codes of practice and safety precautions applicable in the locality should be strictly adhered to. Reference should also be made to the FAA Advisory Circular AC 150/5340-26 'Maintenance of Airport Visual Aid Facilities' for instructions on safety precautions.

The equipment should be isolated before any covers are removed, as high voltages exist within the product and PCBs. A padlock should be used to prevent access to the interior of the sign. Padlock points are available across the top of the facia for this purpose.

The following are examples of statutory regulations which **MUST** be complied with in the UK: -

- Electricity at Work Regulations 1989
- Electricity Supply Regulations 1988
- Health and Safety at Work Act 1974
- Management of Health and Safety at Work Regulations 1999
- Hazardous Waste (England and Wales) Regulations 2005
- European Hazardous Waste Directive (91/689/EEC), or relative national hazardous waste legislation

RESUSCITATION

Maintenance personnel should familiarise themselves with the techniques for resuscitation found in first aid manuals.

MANUAL HANDLING

Due to the length of some signs, methods of handling must be considered. Bending or twisting of a sign during handling will cause damage to the sign and possibly injure personnel. Before attempting to handle signs, personnel should familiarise themselves with the techniques for such actions and ensure they take the appropriate precautions. Refer also to Table 2-1, for the Sign weights in kg, and their lengths.

TABLE OF CONTENTS

SAFETY WARNING	1-1
TABLE OF CONTENTS	1-2
INDEX OF FIGURES	1-2
INDEX OF TABLES	1-2
AMENDMENT CONTROL	1-3
1 GENERAL INFORMATION	1-4
1.1 Introduction	1-4
2 INSTALLATION	2-1
2.1 Mechanical.....	2-1
2.1.1 Introduction	2-1
2.1.2 Manual Handling	2-1
2.1.3 Installing signs using the foot and frangible coupling	2-1
2.1.4 Fixing signs to the poles	2-3
2.2 Electrical	2-6
2.2.1 Introduction	2-6
2.2.2 CCR set-up procedure	2-6
3 COMMISSIONING	3-1
3.1 General	3-1
4 MAINTENANCE	4-1
5 FAULT FINDING.....	5-1
6 PARTS LIST.....	6-1

INDEX OF FIGURES

FIGURE 2.1 SIGN ON A CONCRETE BASE WITH THE FOOT & FRANGIBLE COUPLING	2-2
FIGURE 2.2 MOUNTING FOOT	2-2
FIGURE 2.3 FRANGIBLE COUPLING	2-3
FIGURE 2.4 FIXING DETAILS	2-4
FIGURE 5.1 SETTING TO MATCH THE NUMBER OF LED MODULES CONNECTED	5-2
FIGURE 5.2 OPEN CIRCUIT LED FAULT DETECTION TESTING AND RESET	5-2
FIGURE 5.3 PSU MODULE OPEN CIRCUIT FAULT DETECTION SWITCH SETTINGS	5-3

INDEX OF TABLES

TABLE 2-1 SIGN WEIGHTS.....	2-1
TABLE 2-2 MOUNTING POLE DETAILS, MODE 2	2-5
TABLE 2-3 MOUNTING POLE DETAILS, MODE 3	2-5
TABLE 5-1 FAULT FINDING TABLE	5-1
TABLE 5-2 PSU 'QUANTITY SETTING' ROTARY SWITCH POSITION	5-2
TABLE 6-1 SPARE PARTS LIST	6-1

atg airports ltd
IR858 Single Sided LED Airfield Guidance
Signs Installation and Maintenance Manual

AMENDMENT CONTROL

Issue	Date	Author	Amendment description	Technical Approval	Approved for issue by
1	30/04/18	I Schofield	First Issue		
2	13/12/19	S Robinson	Table 1 – Sign Weights completed	N. Allister	R. Everett
3	6/01/20	S Robinson	IP rating added	N. Allister	R. Everett
4	12/05/20	S Robinson	Open circuit detection added	N. Allister	R. Everett
5	09/12/20	S Robinson	Power supply part number added to spares list	N. Allister	R. Everett
6	12/04/22	P. Craven	Reference to TMSE removed, various text changes, additional information on power supply module	N. Allister	R. Everett
7	8/06/23	P. Craven	Text change regarding insulation testing, section 2.2.1	R. Everett	A. Sole
8	24/06/24	A. Sole	Compliance and document Review	A. Sole	R. Everett

1 General Information

1.1 Introduction

ATG Airports Ltd **IR858** LED signs are manufactured in four electrical formats:

- i. Constant current supply, variable brilliancy (dimnable), fed from an AGL series circuit via an isolating ground transformer, over the range from 2.8A to 6.6A AC at the input to the sign.
- ii. Constant current supply, constant brilliancy, fed from an AGL series circuit via an isolating ground transformer, over the range from 2.8A to 6.6A AC at the input to the sign.
- iii. Mains supply – 220V AC. Constant brilliancy
- iv. 24V DC supply. Constant brilliancy

For the constant current types, the AGL series circuit must be supplied from a Constant Current Regulator (CCR), which should be carefully set up to suit the total load on the circuit. TMSE constant voltage sources are not suitable to be used with the **IR858** Constant Current type LED signs.

The LED sign is designed so that it should give a long and trouble-free operation; this is achieved by using sealed LED Modules which are connected by a Bus wire system. This design methodology allows the device to achieve its maximum expected life and gives added redundancy to the overall system. The LED's have an expected lifetime of 75,000 hours when operated at maximum brilliancy, however a longer lifetime may be expected when operated at lower brilliancies.

2 Installation

2.1 Mechanical

2.1.1 Introduction

ATG Airports Ltd **IR858** signs require installing onto a concrete base, using foot mounts, frangible couplings & 60mm diameter aluminium poles. The sign is secured to the poles using the supplied brackets.

2.1.2 Manual Handling

Signs can be up to 3 metres long and weigh up to 77kg. Consideration must be given to the correct handling methods before attempting to install the sign. A full list of sign lengths and weights is given in Table 2-1 below:

Sign length, mm	685	985	1285	1585	1885	2185	2485	2785	3000
Weights (kg) of 685mm high signs	19	23.5	28	33	38	43.5	49	54.5	60
Weights (kg) of 885mm high signs	24	30	36	42	49	56	63	70	77

Table 2-1 Sign Weights

2.1.3 Installing signs using the foot and frangible coupling

A level concrete base should be constructed as appropriate for the size of the sign. The foot can then be secured to the concrete base using the appropriate bolts.

The number of poles and the distance between them depends on the length and height of the sign and the mode type (See FAA AC150/5345-44K.) Mode 2 signs are designed to withstand a wind speed of 200mph (322kph). Mode 3 is designed to withstand a wind speed of 300mph (483kph). The number of poles required for each mode type is provided in Table 2-2 and Table 2-3.

- **It is absolutely imperative that, when more than two poles are required, all the poles must be mounted exactly in line. If this is not done, fastening the sign to the poles can cause twisting and damage to the sign.**

When the foot mounting has been secured to the concrete base, screw the frangible coupling into the foot until hand tight. Using a 70mm spanner or similar tool, apply an additional one quarter turn to fully secure the coupling in place. Insert the poles into the frangible coupling and tighten the four hexagon bolts on the side of the coupling.

atg airports ltd
IR858 Single Sided LED Airfield Guidance
Signs Installation and Maintenance Manual

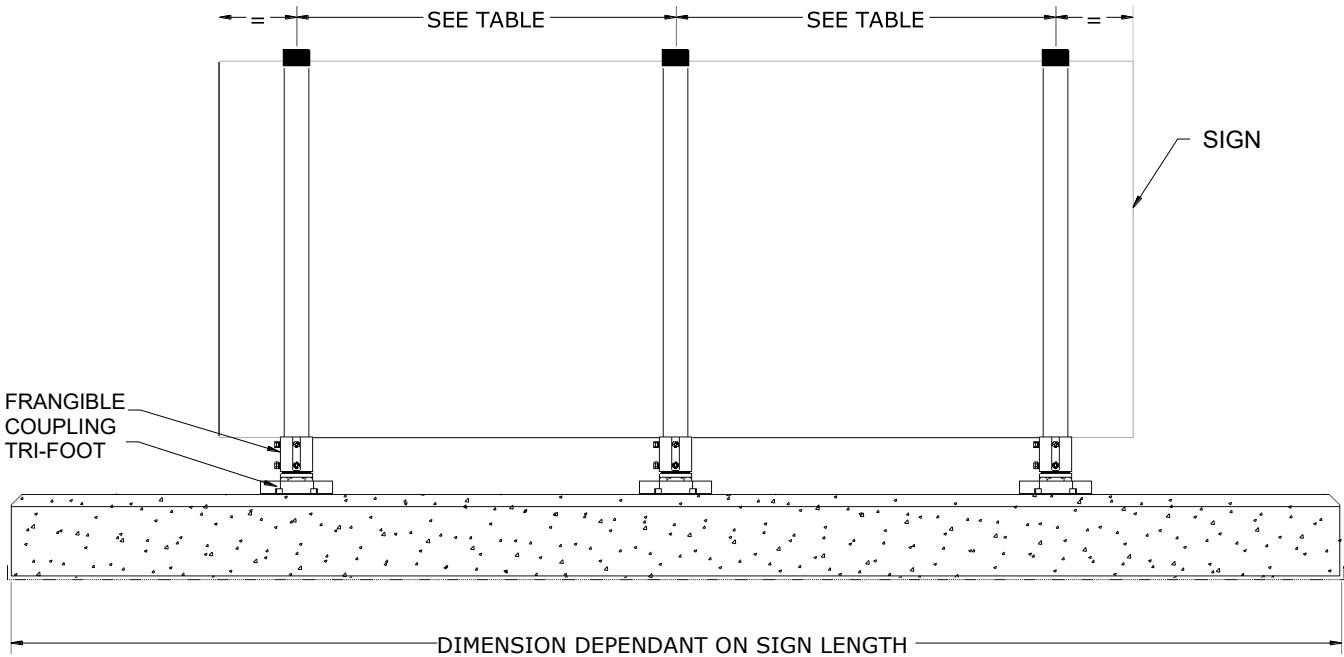

Figure 2.1 Sign on a concrete base with the foot & frangible coupling

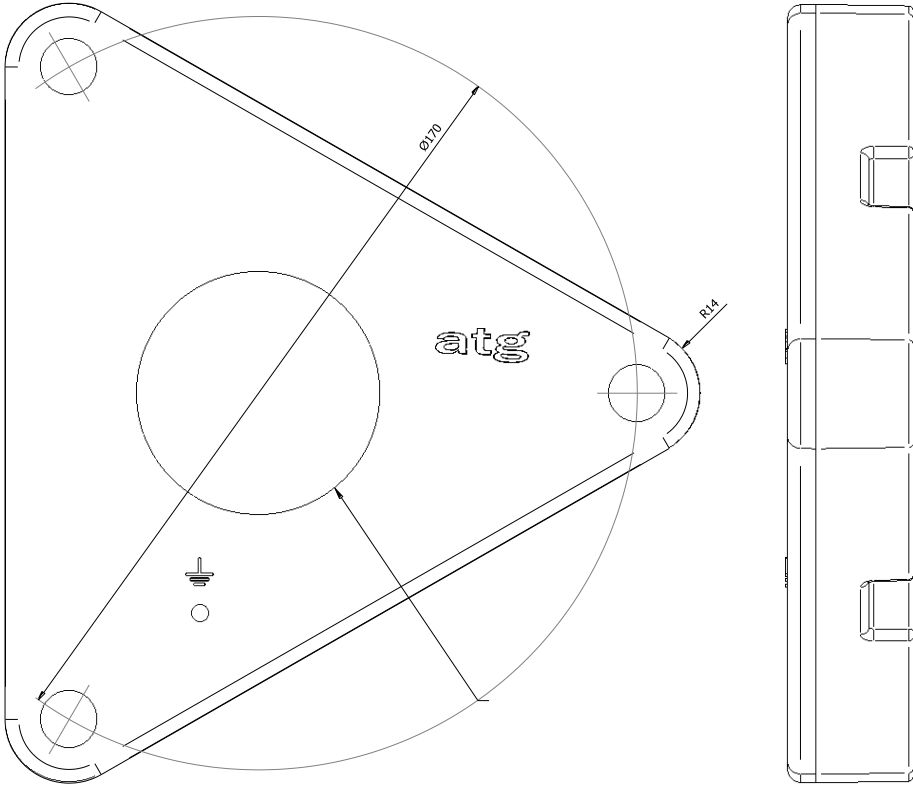

Figure 2.2 Mounting Foot

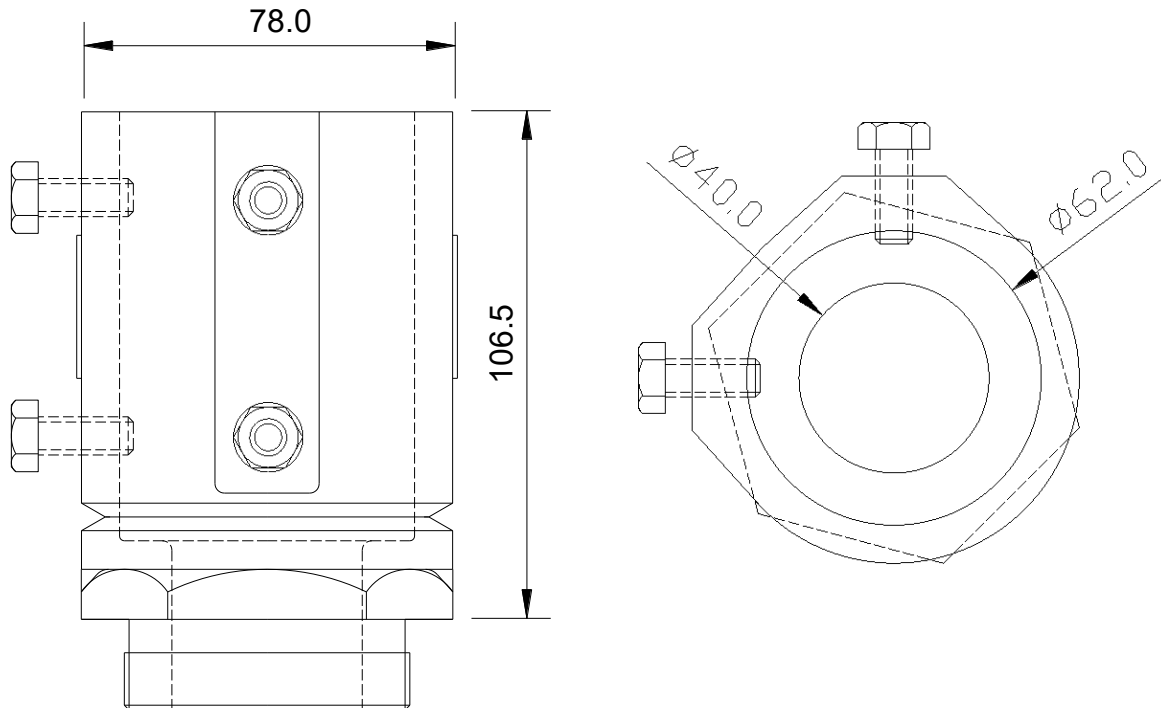

Figure 2.3 Frangible coupling

2.1.4 Fixing signs to the poles

- **Great care should be taken when handling long signs to ensure that the sign body does not twist in any way, as this may result in damage to the sign.**

Lift the sign vertically against the poles and support it off the ground on wooden blocks or similar, so that the top of the sign is at its correct height. Position the sign so that the distance from the end of the sign to the pole at both ends is equal. The sign should then be set such that it slopes very slightly to one end. This will ensure that any condensation which may form inside the sign will drain out. (Slope of 1:100).

Attach the fixing bracket around the pole and position onto the bottom lower mounting 'U' profile on the back of the sign. Fasten lightly until it just grips the sign. Repeat for the bottom bracket on each pole on the sign, then the top bracket for each pole.

Check that the sign is in its correct position and adjust if necessary. Tighten all the clamps on the poles and remove any packing from beneath the sign, ensuring that there is no movement on the poles.

Finally fit the plastic cap over the top of each pole.

atg airports ltd
IR858 Single Sided LED Airfield Guidance
Signs Installation and Maintenance Manual

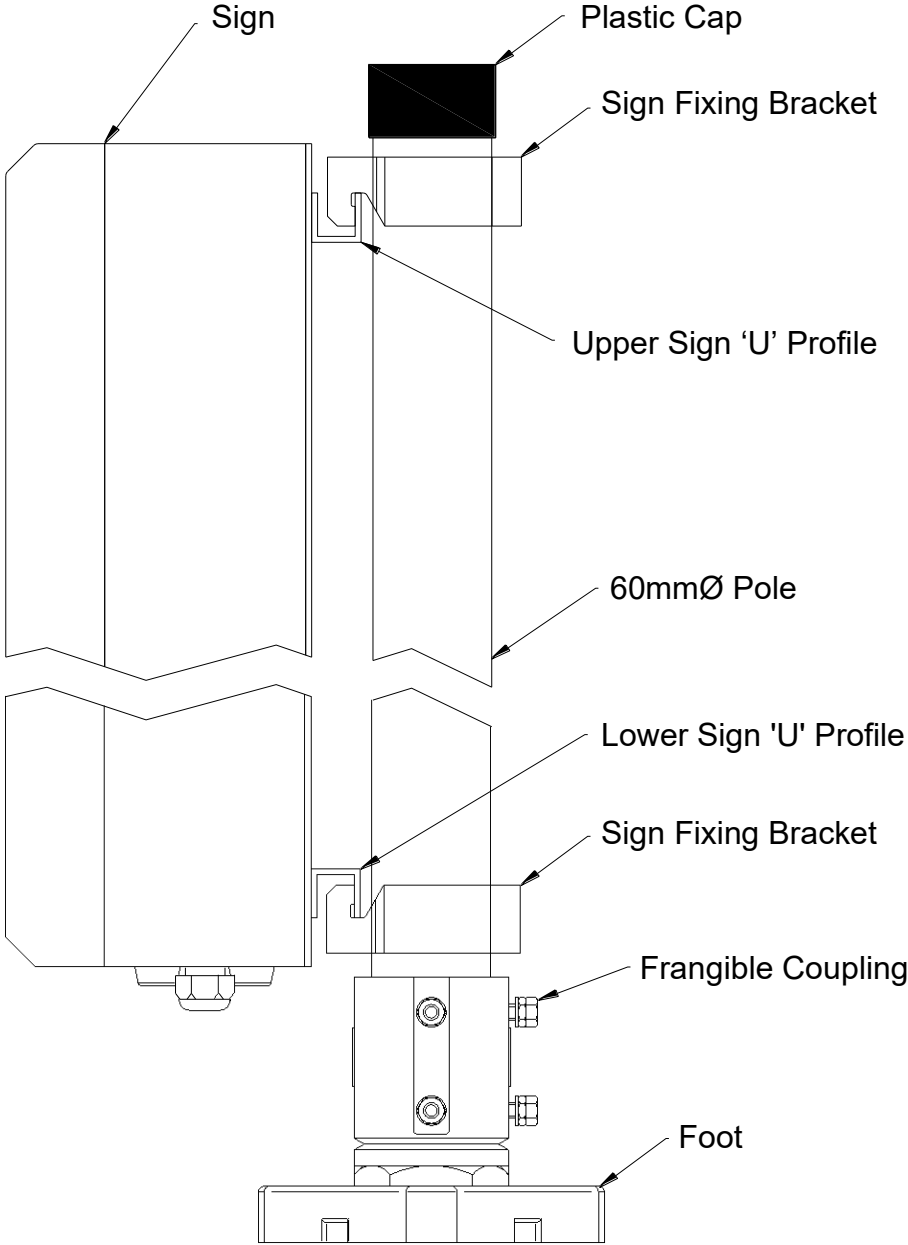

Figure 2.4 Fixing Details

atg airports ltd
IR858 Single Sided LED Airfield Guidance
Signs Installation and Maintenance Manual

685 High Sign: Pole Mounting Distances. Mode 2 (200mph)		
Sign Length (mm)	No. of poles	Separation distance (mm)
685	2	320
985	2	520
1285	2	895
1585	2	1195
1885	2	1520
2185	3	910
2485	3	1065
2785	3	1215
3000	3	1377

885 High Sign: Pole Mounting Distances. Mode 2 (200mph)		
Sign Length (m)	No. of poles	Separation distance (mm)
985	2	520
1285	2	895
1585	3	597
1885	3	760
2185	3	910
2485	4	710
2785	4	810
3000	4	918

Table 2-2 Mounting pole details, Mode 2

685 High Sign: Pole Mounting Distances. Mode 3 (300mph)		
Sign Length (mm)	No. of poles	Separation distance (mm)
685	2	320
985	2	520
1285	2	895
1585	2	1195
1885	2	1520
2185	3	910
2485	3	1065
2785	3	1215
3000	4	918

885 High Sign: Pole Mounting Distances. Mode 3 (300mph)		
Sign Length (m)	No. of poles	Separation distance (mm)
985	2	520
1285	3	448
1585	3	598
1885	4	507
2185	4	607
2485	5	533
2785	6	486
3000	6	551

Table 2-3 Mounting pole details, Mode 3

2.2 Electrical

2.2.1 Introduction

WARNING – TESTING OF ELECTRONIC DEVICES

LED signs contain electronic components that can be damaged by high voltages. To avoid inadvertent damage to the electronic components, including premature failure, signs **must not** be subjected to a high voltage insulation resistance test directly at the input connections to the sign. Failure to comply with this could cause premature failure and invalidate any warranty.

However, periodic insulation testing of the primary series circuit using a 1000V DC or 5000V DC Megger or pressure tester should not cause any damage to the sign provided that the primary to secondary insulation of the isolation or ground transformer feeding the sign is in good condition, and the transformer is correctly earthed.

All signs are supplied fully set up and require no 'on site' commissioning. It is however recommended that once the sign has been fitted in place, it is checked to ensure that all IR858 LED Modules are fitted correctly.

2.2.2 CCR set-up procedure

To ensure the correct operation of signs designed to be supplied from a Constant Current airfield series circuit, it is necessary to correctly set-up the CCR that is supplying the circuit. This should be done in accordance with the relevant manufacturer's instructions.

The sign should be connected to the secondary side of the isolating ground transformer(s). The recommended VA rating of the transformer(s) to be used will be written on the sign nameplate label, fixed to the outside of the enclosure.

3 Commissioning

3.1 General

Once installed all connections, irrespective of the type of sign, should be checked to ensure they are tight.

ATG Airports Ltd **IR858** LED signs are supplied ready to use and as such require no adjustment when they are put into service. Ensure, however, that the correct power supply is provided to the sign, according to the type being installed:

- i. Constant current supply, variable brilliancy (dimmable), fed from an AGL series circuit via an isolating ground transformer, over the range from 2.8A to 6.6A AC at the input to the sign.
- ii. Constant current supply, constant brilliancy, fed from an AGL series circuit via an isolating ground transformer, over the range from 2.8A to 6.6A AC at the input to the sign.
- iii. Mains supply – 230V AC. Constant brilliancy
- iv. 24V DC supply. Constant brilliancy

For the constant current types, the AGL series circuit must be supplied from a Constant Current Regulator (CCR), which should be carefully set up to suit the total load on the circuit. TMSE constant voltage sources are not suitable to be used with the **IR858** Constant Current type LED signs.

4 Maintenance

Ensure that the sign is safely isolated before removing the sign front or working inside the sign cabinet.

Generally, all signs from the *IR858* brand are maintenance free except for occasional cleaning of the front face.

The cabinet and front frames are epoxy powder coated and the panel front is acrylic. The seals are neoprene cell rubber and give a high degree of protection against chemicals used on an airport. However, a yearly lubrication with a silicon-based lubricant is recommended.

All signs from the *IR858* range have been tested for an IP rating in excess of 55.

NOTE. The drain valves fitted in the bottom corners of the sign are there to remove any condensation build up within the sign. These drains are bi-directional and consequently, they will allow air and water in as well as out.

External Cleaning:

The sign front is normally self-cleaning, in so much that rainfall will wash general dust and bird droppings off. In areas of low rainfall, the front panel and cabinet can be washed with a soft sponge and mild soap and then rinsed in cold water to avoid streaking.

Internal Cleaning:

If necessary internal surfaces can be wiped over with a soft cloth to remove dust etc. The front facia legend is ink printed on the internal face.

Great care must be taken not to scratch the facias internal surface.

LED Module exchange: To replace the LED Module cut the bus wires either side of the faulty module and replace with a new module using inline crimps. Ensure that the polarity of the connections is correct.

Power Supply Exchange: To replace the power supply unplug the wires from the unit and replace faulty unit with new. Then reconnect the wires and set the rotary selector switch to the correct number of LED Modules connected to this power supply unit.

Sign Front Removal: If it becomes necessary to remove the sign front (Frame & Facia) the sequence of removal is as follows. Undo the hasp & clasp on the top of the sign. Remove the screws holding the support stays to the front frame. Then lower the front frame to at least 90 degrees from the vertical. The front frame can then be removed by sliding to either the left hand or the righthand sides. To replace the front, reverse this operation.

Great care must be taken not to scratch the facias internal surface.

atg airports ltd
IR858 Single Sided LED Airfield Guidance
Signs Installation and Maintenance Manual

Drain valve: These valves can, over time, become blocked due to environmental pollution. Remove them by unscrewing from underneath and wash out in warm soapy water. Replace when clean.

Bird deterrent: Signs are optionally delivered with a bird deterrent string system. Any thin stainless-steel cable may be used for this purpose. Insert the string into the small holes and stretch the wire so that it has approximately a 5mm sag in the middle and fix in place with the screw in the top of each post. Do not over-tighten the screw, as it may cut into the wire and break it. Fold down and trim any loose ends of the wire as necessary.

5 Fault finding

WARNING - BEFORE ANY WORK IS UNDERTAKEN WITHIN THE SIGN, SWITCH OFF AND ISOLATE THE POWER TO THE SIGN.

Fault	Possible cause	Solution
Sign is not lit (live circuit)	AGL Transformer not connected	Check input connections.
Sign is partially lit	Loose connection	Check all wiring is correctly fitted.
	Individual LED Module or Power supply unit faulty.	Replace faulty Unit (see below table).
Sign has reduced brightness	CCR not correctly setup	Although the sign should not be damaged by high crest factors, the LED sign will perform optimally when the CCR is setup so that at the maximum brilliancy step the crest factor does not exceed 2.
	CCR current step not set to maximum	The sign is designed to dim as selected by the brilliancy step on the CCR.
	Ground transformer faulty or inadequately rated.	Replace the ground transformer, ensuring that the power rating matches that stated on the sign rating plate.
Water in bottom of sign	Condensate water	Unscrew drainage plug and remove any articles in the plug. Clean or replace with a new plug.
	Gasket is leaking	Gasket shall be consistent throughout the opening face. If gasket has broken, clean surface and add gasket for the distance where missing.
	Door is not properly closed	Close the door with all locks. Important! It is vital that the locks are not tightened too much. The gasket fits exactly into the front frame and it will not help to tighten more than necessary.

Table 5-1 Fault finding table

LED Module exchange: To replace the LED Module cut the bus wires either side of the faulty module and replace with a new module using inline crimps. Make sure you get the polarity correct.

Power Supply Exchange: To replace the power supply disconnect the wires from the unit and replace the faulty unit with a new one. Then reconnect the wires and set the LED Module 'Quantity Setting' rotary switch to correctly match the number of LED Modules connected (in parallel) to the DC Output from the power supply unit (see the photographs below). This will set the correct minimum current level fault threshold to turn off the sign in the event of one or more of the parallel connected LED Modules failing open circuit. Note – the open circuit detection feature - if required - should be enabled using DSW1; see the following page.

atg airports ltd
IR858 Single Sided LED Airfield Guidance
Signs Installation and Maintenance Manual

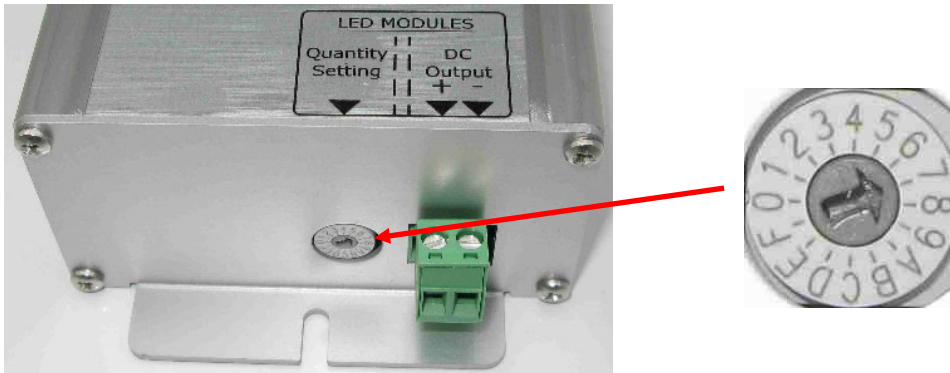

Figure 5.1 Setting to match the number of LED Modules connected

The PSU 'Quantity Setting' rotary switch should be set as shown in Table 5-2 below:

Number of LED Modules connected to PSU	1	2	3	4	5	6	7
Variable brilliancy sign – rotary switch position	1	2	3	4	5	6	7
Constant brilliancy sign – rotary switch position	8	9	A	B	C	D	E

Table 5-2 PSU 'Quantity Setting' rotary switch position

Open Circuit LED Fault Detection: If current is being supplied to the sign input, but current is not flowing through the input terminals to the PSU module, it could be that the open circuit LED fault detection (if enabled – see overleaf) has opened the relay contacts at the input to the module. This can be verified using an ammeter, as shown in Figure 5.2 below. The internal relay can be bypassed and reset by placing a wire link (suitable for 6.6A AC) between the terminals labelled 'External Reset', shown on the right side of the photograph below. Note – if an LED Module has failed open circuit, the detector will repeatedly trip and cause the input relay contacts to open.



Figure 5.2 Open Circuit LED Fault Detection testing and reset

atg airports ltd

IR858 Single Sided LED Airfield Guidance Signs Installation and Maintenance Manual

Enabling of the Open Circuit LED Fault Detection: The 2-pole DIP switch DSW1 on the AT1025 power supply module pcb is used to enable (DSW1-1) and set the sensitivity (DSW1-2) for the open circuit LED Module fault detection. This is based on measuring the output current to the parallel connected LED Modules, and if the current falls below a minimum threshold, then an open circuit fault condition is triggered. The current threshold for the fault detection varies with the LED output current demand level (dependant on the CCR supply current), the number of LED Modules connected and the sensitivity of the detector, set by the position of DSW1-2.

The factory setting is for the open circuit LED Module fault detection to be disabled, by setting the DIP switches for both DSW1-1 and DSW1-2 to be 'OFF', that is, both actuators down.

With DSW1-1 set to the 'ON' position (left hand actuator up) and DSW1-2 to 'OFF' (right hand actuator down), then the controller will trip out with 1 LED Module failed open circuit out of the total number connected.

With DSW1-1 and DSW1-2 both set to the 'ON' position (up), then the controller will continue to operate with 1 LED Module failed open circuit, but will trip out with 2 LED Modules failed open circuit.

To gain access to switch DSW1 on the AT1025 card it is necessary to remove one of the endplates from the power supply module by removing the four fixing screws and sliding out the lid; see the photographs below:

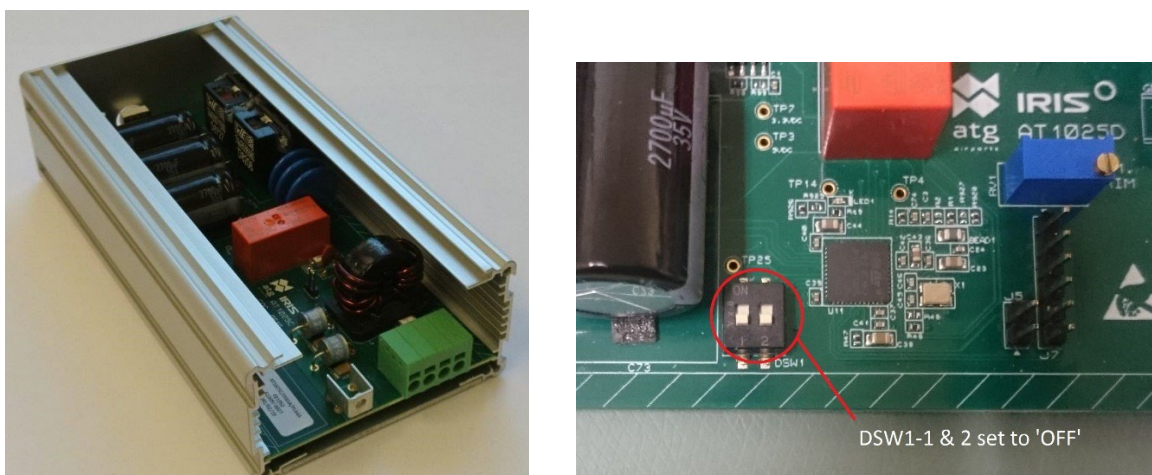

Figure 5.3 PSU Module Open Circuit Fault Detection switch settings

Luminance Trim potentiometer: The blue potentiometer RV1 shown above can be used to adjust the current supplied to the LED Modules. This is normally set fully clockwise; turning fully anti-clockwise reduces the LED current to 50% of the standard value at any given brilliancy level.

6 Parts list

Item description	atg part number
Mounting Foot	009146
Frangible Coupling	009121
Aluminium pole 60mm diameter	2670-1277
Plastic cap (Yellow)	3120-0115
Plastic cap (Black)	3120-0116
Sign fixing bracket	2670-1280
Front panel clasp	2675-0021
Front panel hasp	2675-0022
Drain valve	2675-0125
LED Module	021032
AGL Supply Cable	2670-9001
Cable Gland	2655-0015
Power Supply Unit	021052

Table 6-1 Spare parts list