



ZM203I

Seating Pot - 8 inch

Compliant to Latest International Standards*

- ▶ ICAO Annex 14. Vol 1
- ▶ FAA AC 150/5345-42G
- ▶ IEC 61827

Applications

For the installation of 8" AGL light fixtures

* As applicable to the application, compliance with other civil aviation and military regulations confirmed on request

† Electrical/Mechanical/Environmental characteristics only

ZM203I

8" Shallow base seating pot

Features

The atg airports ZM203I mounting shallow base consists of an aluminum casting with a hole at the bottom of the base can which is suitable for installation of cables. As an alternative, the shallow base can be sealed and equipped with one or two glanded cable entry points to facilitate connections to the light fixture. The aluminium base can is treated with a two-pack acrylic enamel paint which, is a paint system involving an acrylic paint melamine, and a hardener resin. When combined, these two resins result in a chemical reaction producing a hardened solution helping to prevent porosity and water ingress.

The shallow base is designed for installing in situ by means of epoxy-resin secured in a core that has been drilled in the pavement or into a precast concrete block. With the dry base option, a gasket (separately supplied) must be placed between base and fixture for water tightness. All hardware for fixing, screw and washer, are in stainless steel. On request customized version are available.

With this type of shallow base installation, the isolating transformer used to power the fixture, along with the the primary circuit connectors, are typically located in a pit at the edge of the runway or taxiway. The light is powered by means of a secondary cable being installed from the pit to the light base.

There is currently no regulation specifically covering the requirements for these types of shallow bases. However, the base cans are designed in compliance with the mechanical and environmental requirements of IEC 61827 and the FAA AC 150/5345-42 specifications.



Environmental Conditions

- ▶ Ambient Temperature -55 °C to +55°C (-67 °F to +131°F)
- ▶ Storage Temperature -55°C to +70°C (-67 °F to +158°F)
- ▶ Atmospheric Altitude up to 10,000 feet (3000m)

Standards	
ICAO Annex 14	Volume 1
FAA	150/5345-42G
IEC	61827

ZM203I

8" Shallow base seating pot

Ordering Codes: ZM 203I

Application

Shallow base can - 8"

Type

1 = dry
2 = wet

Cable entry points (dry only)

0 = NA
1 = One
2 = Two

Additional optional features are available upon request

Dimensions

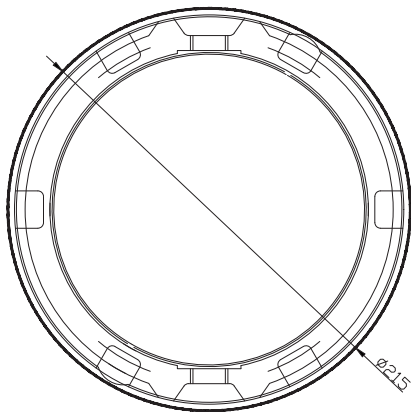

TOP VIEW

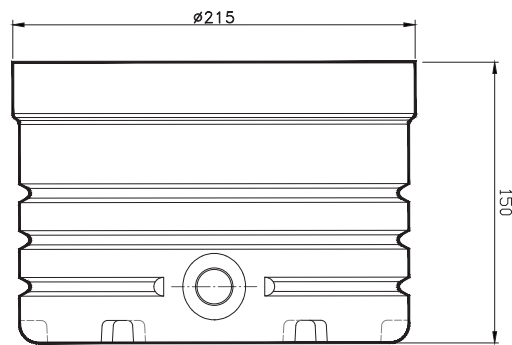

SIDE VIEW

Packaging

▶ Net weight 4.36Kg ▶ Gross weight 4.70 (boxed) ▶ Box 250mm (L) x 250mm (W) x 180mm (H)



Head Office:

atg airports ltd

Lowton Business Park | Newton Road
Lowton St. Mary's | Warrington
WA3 2AP | United Kingdom

atg airports reserve the right to change technical data and details at any point in time. Errors may have occurred



UK: +44 (0) 1942 68 5555 | USA: +1 (239) 985-9406

www.atgairports.com enquiries@atgairports.com sales-usa@atgairports.com

ZM203I