

Tungsten halogen technology



ZA737 3 lamp

ZA757 2 lamp

Precision approach path indicator

## Features

- ▶ ICAO 30° wide beam to obtain full advantage of MLS and to provide visual aid to touchdown. Circulating airflow minimises cold weather condensation effects on beam performance. Lens heaters included with lamp circuit to provide even dispersions of condensation
- ▶ Developed by Royal Aircraft Establishment at Bedford, UK
- ▶ Acquisition range: normal day 19km with met visibility 7.4km (see table)
- ▶ Easy maintenance whilst in service position. Lamp change via access hatches at the rear of the PAPI
- ▶ No special tools or instruments required for servicing. Optical bench not required
- ▶ Three leg mounting for ease of levelling and elevation setting with natural stability built in for high wind and jet efflux conditions
- ▶ Constant frangible facilities, regardless of mounting height
- ▶ Lenses protected from driving rain and splashing. No front window to keep clean Glare reduction as pilot approaches and passes threshold.
- ▶ ICAO settings will allow curved approach with offset of up to 6° without amendment to unit.

Approach angles of 1° to 12° can be catered for.

- ▶ Long life halogen lamps with a typical life of 1500 hours at full intensity or over 3500 hours in normal usage
- ▶ Powder coat paint finish in golden yellow. All fasteners are stainless steel
- ▶ Water ingress rating minimum IP54
- ▶ IMM available on request

## Compliance with standards

ICAO	Annex 14 fig 2.23
CAA	CAP168 fig 6A/18
NATO	STANAG 3316
BSI	BS3224 Part 1

## Application

Precision Approach Path Indicator (PAPI) units provide two colour (red/white) approach path information from a wingbar arrangement. Fully operational from 100% to 0.3% brilliancy, giving typically 3000 hours of useful lamp life. The ZA737 is a three lamp unit, the ZA757 is a two lamp unit. Both have identical 2' to 3' of arc transition performance. Three lamp units allow one lamp out per unit, still leaving a fully operational wingbar.

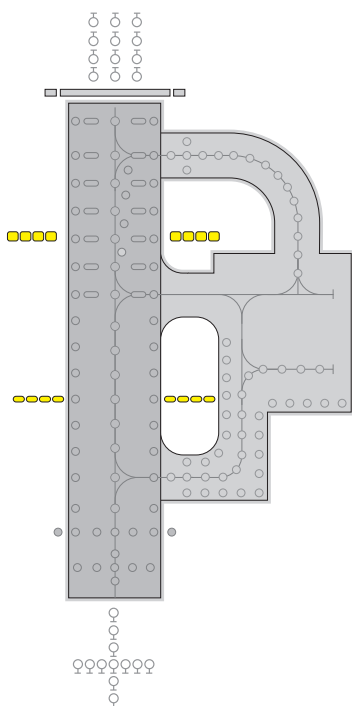

ZA737 3 lamp  
ZA757 2 lamp

UK: +44 (0) 1942 68 5555 | USA: 001 (239) 985-9406

www.atgairports.com enquiries@atgairports.com sales-usa@atgairports.com

## Options

- Alternative lamp wattages available if required to balance requirements
- Converted to CHAPI by inserting CHAPI filter gate
- FAA version available
- Lamps ZA737 (three off), ZA757 (two off), J1/39 200W, 6.6A or PK30 lamp (150W or 200W) versions available
- Sighting platform/levelling set
- Inclinometer
- Rigid concrete block mounting system

## Electrical supply

Suitable for all normal series circuit systems of 6.6A, 8.33A, 12A, 16A or 20A. Can also be used on systems via voltage transformers 240V/120V 50/60Hz.

## Packaging data

### ZA737 (PAPI Unit)

Net weight	25kg
Gross weight	34kg
Carton size	1210mm(w) x 825mm(d) x 385mm(h)

### ZA757 (PAPI Unit)

Net weight	19kg
Gross weight	24kg
Carton size	1210mm(w) x 565mm(d) x 385mm(h)

### ZM130 (Mounting Base)

Net weight	5.5kg
Gross weight	7kg
Carton size	1008mm(w) x 825mm(d) x 165mm(h)

### ZM131 (Mounting Base)

Net weight	5kg
Gross weight	6.5kg
Carton size	1008mm(w) x 565mm(d) x 165mm(h)

## Components

1	Side cover (yellow)	Not saleable
2	Fixed top cover (yellow)	Not saleable
3	Removable top cover (yellow)	Not saleable
4	Side cover (yellow)	Not saleable
5	Hatch cover	SLC21077
6	Back cover (yellow)	28396A
7	Bottom cover (black)	28390
8	ZM130/1 Base unit assembly (3 lamp)	27152
9	Set of 3 x 1m legs (black)	SLC21046
10	H Frame	28660F
11	Cable gland	25437
12	Locknut	Cat No. 93
13	540mm Plug lead	SLC13006
14	Terminal block	BK3
15	ZB017/2 Lampholder (PK30 option available)	SLC15053
16	Heatsink plate	27140A
17	Reflector	028052
18	Back plate (black)	Not saleable
19	Filter spring	27076
20	Spirit level packing strip	28355
21	CHAPI filter glass set	SLC21096
22	PAPI filter (red)	SLC19035
23	Lens mounting strap	27131
24	Lens heater	SLC21186
25	Lens	SLC16040
26	Front plate (black)	Not saleable

*SLC No's available as optional spares*

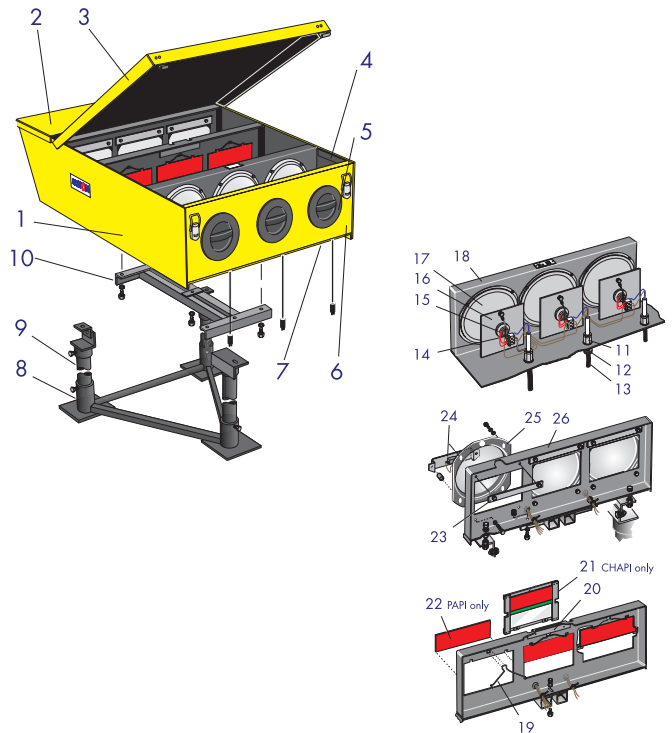

UK: +44 (0) 1942 68 5555 | USA: 001 (239) 985-9406

www.atgairports.com enquiries@atgairports.com sales-usa@atgairports.com

**ZA737** 3 lamp  
**ZA757** 2 lamp

# Typical installation methods

## Foundation details

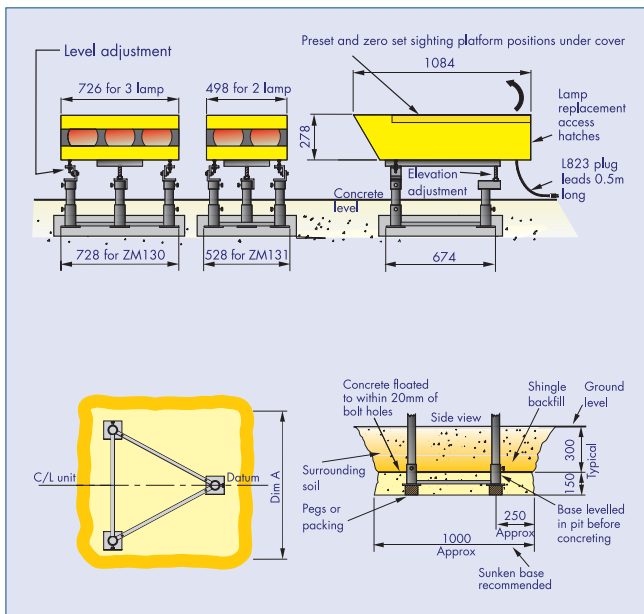

# Photometric performance

## P.A.P.I (two lamp performance)

ZA757 Isocandela lines for white light = red light x 5 (Candelas)

### Nominal Lamp Details

Power 2 x 200 Watts  
 Current 6.6 Amps  
 Type J1/39

### Specification

I.C.A.O FAA, Annex 14 AC No. 150/5345 -28D, Fig 2.23 46B  
 (CAP168 Photometrics not shown)

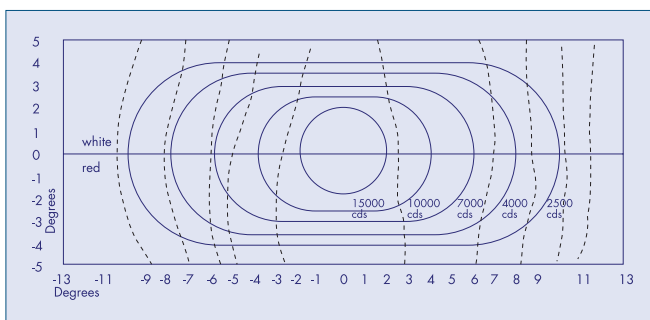

**Head Office:**  
**atg airports ltd**  
 Lowton Business Park | Newton Road  
 Lowton St. Mary's | Warrington  
 WA3 2AP | United Kingdom

atg airports reserve the right to change technical data and details at any point in time. Errors may have occurred



UK: +44 (0) 1942 68 5555 | USA: 001 (239) 985-9406

www.atgairports.com enquiries@atgairports.com sales-usa@atgairports.com

**ZA737** 3 lamp  
**ZA757** 2 lamp