

Tungsten halogen technology



# ZA487

Threshold/Runway end

High intensity bi-directional inset fitting

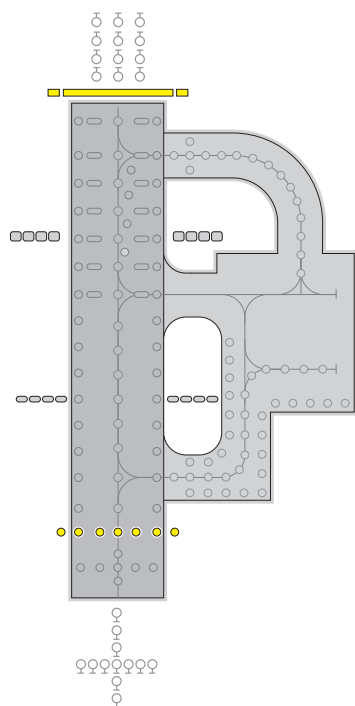

## Features

- ▶ Lightweight and robust due to its aluminium alloy construction
- ▶ Components that are common with ZA181 and ZA280 series
- ▶ Long life halogen lamps with a typical life of 1500 hours at full intensity or over 3500 hours in normal usage
- ▶ Standard adaptor rings to suit 15", 15.5" bases
- ▶ Prism removal and replacement achieved without the need for adhesive or sealants
- ▶ Colour beam variations achieved by dichroic coating
- ▶ Lamp bypass options available when required
- ▶ Pre-focused optics to simplify maintenance procedures
- ▶ Light channel within 5mm of grade
- ▶ Plug for pressure testing
- ▶ Water ingress rating - IP67
- ▶ Low temperature - temperature at centre of top cover remains below 160°C ICAO and FAA limit
- ▶ All fasteners are stainless steel
- ▶ IMM available on request

## Compliance with standards

- ICAO Annex 14
- FAA AC150/5345-46C, L-850A,B,C, D, E Class I & IIB
- NATO STANAG 3316
- CAA CAP168
- Transport Canada MOS 139

## Application

Suitable for use in category I, II and III all weather operation airfield lighting systems as:

- ▶ Combined threshold/end

## Options

- ▶ ZM480 seating pot (wet)
- ▶ ZM480 seating pot (dry)
- ▶ PSA & FAA adaptors
- ▶ ZS023 sighting device
- ▶ ZM500/4 lifting handle
- ▶ ZM480 installation jig

UK: +44 (0) 1942 68 5555 | USA: 001 (239) 985-9406

www.atgairports.com enquiries@atgairports.com sales-usa@atgairports.com

ZA487

## Electrical supply

Suitable for use in 6.6A airfield lighting circuits normally supplied from 100W, 200W or 300W isolating transformers.

## Packaging data

Net weight	9.3kg
Gross weight	10kg
Carton size	50mm(w) x 330mm(d) x 330mm(h)

## Components

- 1 Body casting
- 2 Prism
- 3 Prism gasket
- 4 Prism clamp
- 5 Prism clamp gasket
- 6 Bottom cover gasket
- 7 Bottom cover casting
- 8 'B' type plug lead
- 9 Cable gland assembly
- 10 Cable clamp
- 11 Reflector lamp
- 12 Lampholder
- 13 Lamp retaining spring
- 14 Lamp gasket
- 15 Mounting plates:
- 16 Lampholder support block
- 17 Pressure test plug

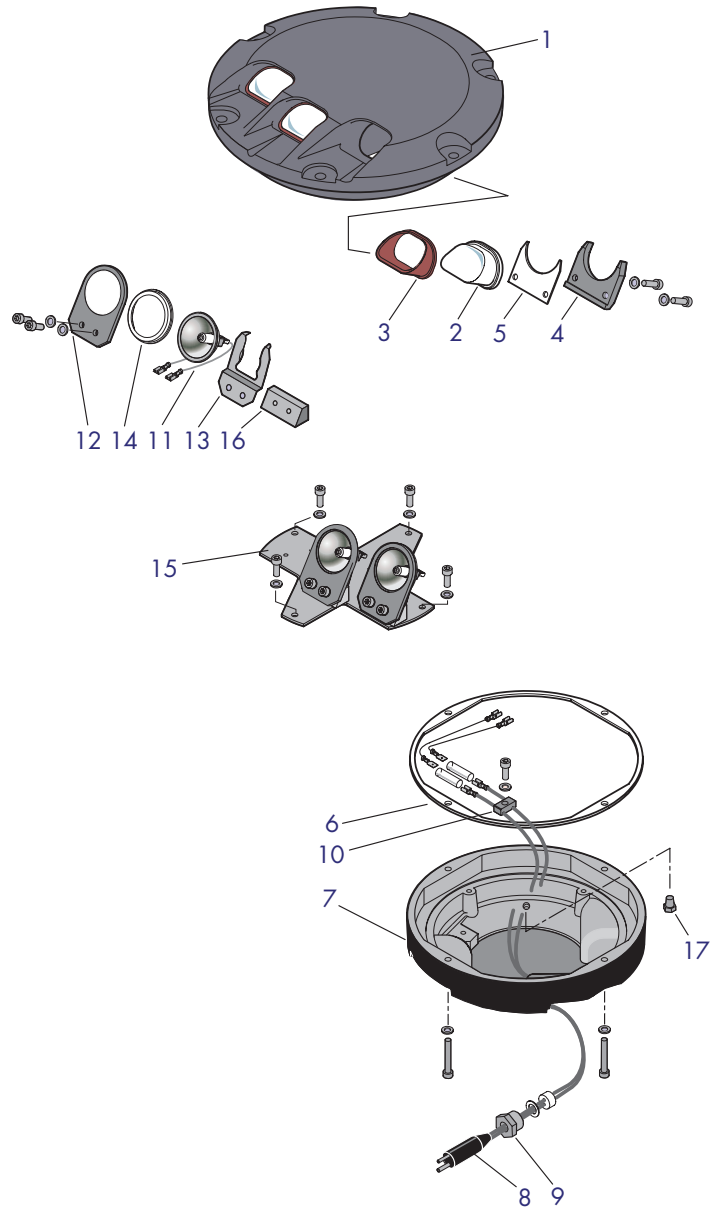

## Typical installation methods

- In a 12" dia seating pot, [atg airports ltd](#) type ZM480

ZA487 Installed in ZM480 Seating Pot (dry version)

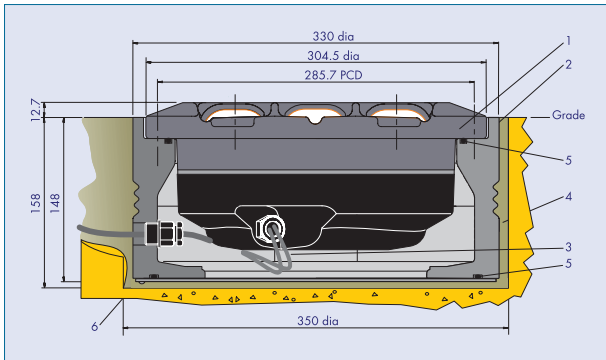

- |                         |                |
|-------------------------|----------------|
| 1. ZA487 Fitting        | 4. Grout       |
| 2. ZM480 Seating Pot    | 5. 'O' Ring    |
| 3. Secondary Connection | 6. Cable Gland |

Note ZM480 Wet seating pot arrangement information available on request.

- In a 12" FAA L-868 Base

ZA487 Installed on FAA L-868 Base

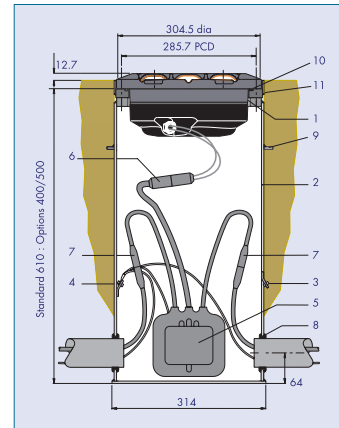

- |                                    |                       |
|------------------------------------|-----------------------|
| 1. ZA487 Fitting                   | 7. Primary connection |
| 2. FAA L-868 Base (one piece)      | 8. Grammet            |
| 3. Outer earth terminal (optional) | 9. Anchor ring        |
| 4. Inner earth terminal (optional) | 10. 'O' Ring          |
| 5. Isolating transformer           | 11. Dam ring          |
| 6. Secondary connection            |                       |

## Specification

ZA487 - combined threshold/end inset high intensity light shall comply with ICAO Annex 14 figs 2.3, 2.4, 2.8 and FAA L-850D Class 1 for use in category I, II and III all weather operations.

Fitting shall be of modular design with the main casting manufactured in aluminium alloy, suitably protected against corrosion and finished in golden yellow or anodised aluminium.

The optical system shall comprise of maximum 3 lamps (2 lamps for threshold, 1 lamp for runway end) rated at 105W 6.6A max. Glass prisms shall be accurately located in the main casting, without the need for additional adhesives or sealants, to direct the light beams such that no re-focusing is required on installation, maintenance or in service. Dichroic coatings shall provide green or red light.

Lamp replacement shall be easily effected from the bottom of the fitting. The objective lamp life at maximum intensity shall not be less than 1500 hours on a constant current series circuit at full intensity. The light fitting shall have an upper surface forming a smooth sloped face projecting not more than 12.7mm above the pavement surface. The fitting shall resist all stresses imposed by impact, rollover and static loads of present day aircraft without damage to the fitting or to aircraft and vehicle tyres.

It shall be fitted with a pressure relief plug to allow pressure testing.

The fitting shall be suitable for installation in the pavement surface in a 12" cast aluminium shallow (150mm max) seating pot, type ZM480 or in 12" FAA L868 deep canisters.

# Photometrics

Threshold/End:

Green	ZA487
Main Ellipse Intensity Measurements (Candelas)	
Average	11546
Min. Average	10000
Max (B)	14433
Min (A)	8405

Nominal Lamp Details	
Power	2x 105 Watts
Current	6.6 Amps
Type	Cold Reflector Lamp
ICAO	CAP168
Annex 14	FIG 6A/3
	FIG 2.3

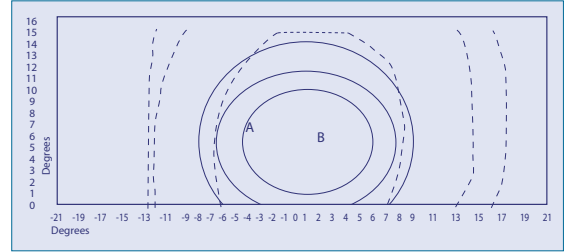

Threshold/End: End performance

Red	ZA487
Main Ellipse Intensity Measurements (Candelas)	
Average	2646
Min. Average	2500
Max (B)	3068
Min (A)	2148

Nominal Lamp Details	
Power	105 Watts
Current	6.6 Amps
Type	Cold Reflector Lamp
ICAO	CAP168
Annex 14	FIG 6A/8
	FIG 2.9

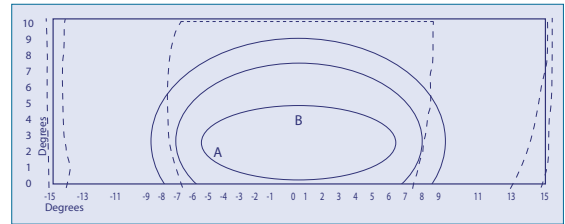

## Orientation

ZA 487 Combined Threshold/End:

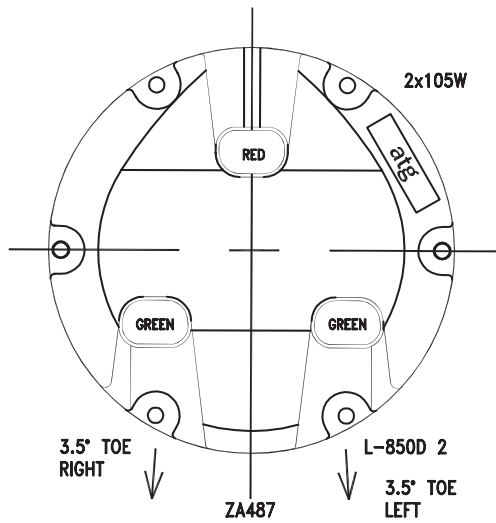

**Head Office:**  
**atg airports ltd**  
 Lowton Business Park | Newton Road  
 Lowton St. Mary's | Warrington  
 WA3 2AP | United Kingdom

**THINK  
 BEFORE YOU  
 PRINT**



atg airports reserve the right to change technical data and details at any point in time. Errors may have occurred

UK: +44 (0) 1942 68 5555 | USA: 001 (239) 985-9406

www.atgairports.com enquiries@atgairports.com sales-usa@atgairports.com

**ZA487**