

Tungsten halogen technology



# ZA181

## Runway Centreline & TDZ

High intensity Bi-Directional inset light

PSA Version

### Features

- Lightweight and robust aluminium alloy construction which also gives good corrosion resistance
- Dichroic coated lenses for coloured light options
- Full range of FAA and PSA adaptors available
- Anti-rotation pin locations
- Left and right toe-in option for TDZ version
- Long life, low energy lamps (1500 hrs/45W or 49W at full brilliancy) - 1 or 2 off per fitting
- Pre-focused optics simplify maintenance procedures
- Light channel within 5mm from Grade
- Two point fixing into mounting adaptor/seating pot for faster installation and removal of light cartridge
- Low profile (12mm) to reduce possibility of damage to aircraft and vehicle tyres
- Twin-lead, bi-directional (switchable) versions available
- Prisms accurately located and secured in the body casting without the need for sealing compound to facilitate removal and replacement
- Optional lamp by-pass devices can be fitted if required
- Generic with ZA280 and ZA292 IEC fittings
- Compatible with IEC seating pots
- Clear anodised.
- All fasteners are stainless steel
- IMM available on request

### Application

Runway centreline or touchdown zone fitting for use in category I, II & III all weather operation airfield lighting systems.

### Options

- ZM203 (I) 8" seating pot (dry and wet)
- BS 12" adaptor flange
- BS 15.5" adaptor flange
- FAA L-868 12" axial adaptor flange
- ZS023 Sighting device
- Extractor tool
- ZM203 (I) installation jig

### Electrical supply

Suitable for use in 6.6A airfield lighting circuits, normally supplied from one 100W/150W or two 45W/65W series circuit isolating transformers.

### Packaging data

Net weight	5kg
Gross weight	6kg
Carton size	220mm(w) x 220mm(d) x 126mm(h)

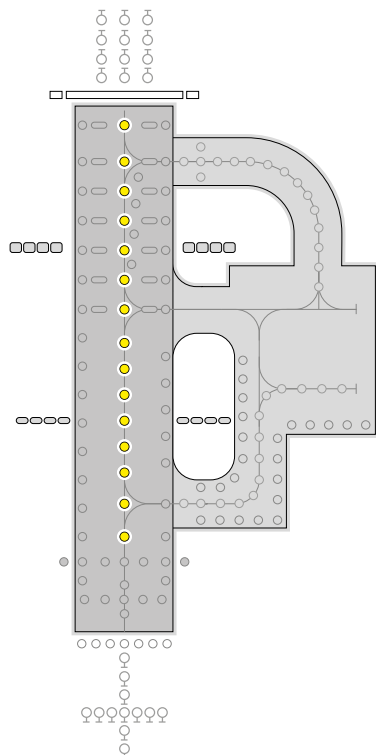

### Compliance with standards

- **FAA** In compliance with FAA L-850A & B, specifications AC 150/5345-46D
- **ICAO** In compliance with ICAO Annex 14, figs 2.5, 2.6, 2.7 & 2.8
- **NATO** In compliance with STANAG 3316
- **CAA** CAP168, figs 6A/5, 6A/6 & 6A/7
- **BS3224** Part 5, inset fittings
- **IEC** 61827
- **EASA** U10, U11

UK: +44 (0) 1942 68 5555 | USA: 001 (239) 985-9406

www.atgairports.com | products@atgairports.com | sales-usa@atgairports.com

ZA181 PSA Version

## Components

1	Body casting (anodised or golden yellow)	Not Saleable
2	Clear prism (1 or 2)	SLC16069
	or red dichroic prism	SLC19141
3	Blank for prism aperture	SLC40092
4	Prism gasket (2)	SLC33058
5	Prism clamp gasket	SLC33069
6	Prism retaining clamp (2)	SLC32037
7	Lampholder (1 or 2)	SLC32040
8	Lamp retaining spring (1 or 2)	SLC32039
9	Cold reflector lamp - 45/49W 6.6A (1 or 2)	SLC08065
10	Lamp gasket	SLC33083
11	Lamp by-pass disc assembly (1 or 2)	DRG28848
12	45W by-pass disc (1 or 2)	SLC21134
13	Seating pot 'O' ring seal	SLC33094
14	Gasket, body to base	SLC33095
15	Lampholder support block	SLC21296
16	Cable gland assembly (1 or 2)	SLC21114/5/6
17	'B' type plug lead (1 or 2)	SLC13001

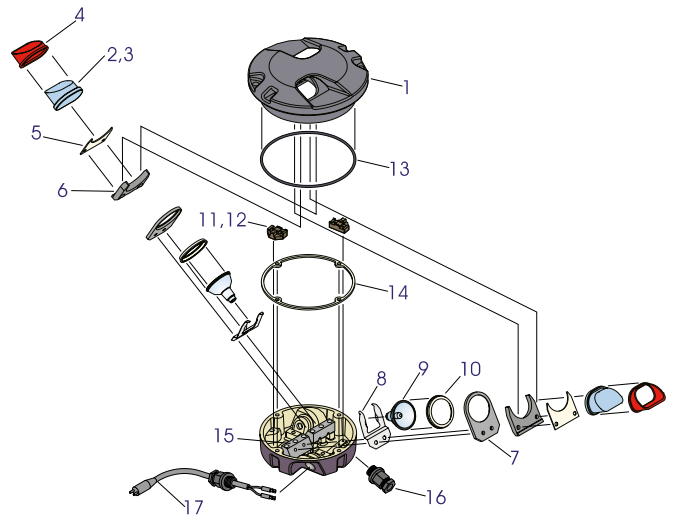

## Typical installation methods

### In 8" dia seating pot

atg airports type ZM203(I). Adaptor rings enable the fitting to be mounted into new or existing standard PSA 12" and 15.5" dia seating rings.

ZA181(I) installed in ZM203(I) seating pot (dry)

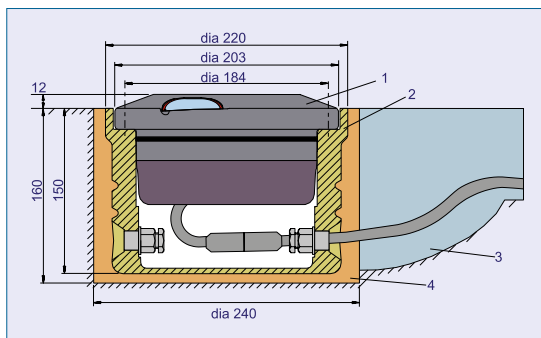

- |                                   |                   |
|-----------------------------------|-------------------|
| 1. ZA181 (I) fitting (F29282)     | 3. Secondary lead |
| 2. ZM203 (I) seating pot (F29276) | 4. Grout          |

### In FAA 12" dia L-868 base

Installation on to FAA L-868 seating base can be achieved by using an 8 -12" adaptor ring.

ZA181(I) installed on FAA L-868 base

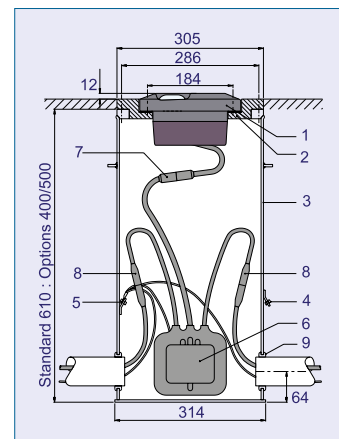

- |                                      |                          |
|--------------------------------------|--------------------------|
| 1. ZA181 (I) fitting (F29282)        | 6. Isolating transformer |
| 2. Mounting adaptor - axial *H29249) | 7. Secondary connection  |
| 3. FAA L-868 base (one piece)        | 8. Primary connection    |
| 4. Outer earth terminal              | 9. Grommet               |
| 5. Inner earth terminal              |                          |

### ZA181(I) General Arrangement

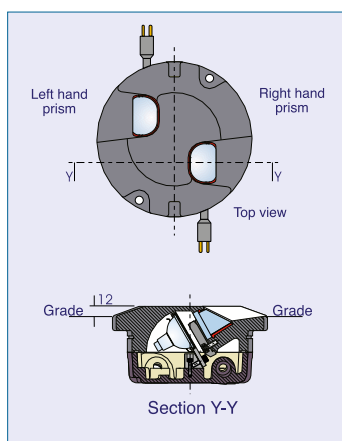

# Photometric performance

## Runway Centreline (15 metres) CAT III:

### Main Ellipse Intensity Measurements (Candelas)

Average	6494
Min. Average	5000
Max (B)	9262
Min (A)	3241

### Nominal Lamp Details

Power	45.0 Watts
Current	6.6 Amps
Type	Cold Reflector Lamp
ICAO	CAP168
Annex 14	FIG 6A.7
FIG 2.7	

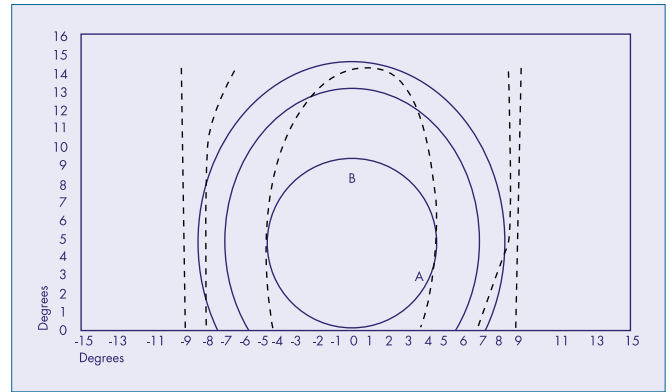

Other photometric information available on request.

## Ordering code

ITEM	COLOUR						PLUG LEAD		LAMP		BYPASS DEVICE		FINISH		MOUNTING ADAPTORS
	Left-hand Side			Right-hand Side			1	2	1	2	N	B	Y	N	
	W (White)	R (Red)	N (Blank)	W (White)	R (Red)	N (Blank)	(B Type Lead, Single)	(B Type Lead, Twin)	(1 Lamp)	(2 Lamp)	(Not Fitted)	(Fitted)	(Golden Yellow)	(Nato Green)	
ZA180(I)	W			W			1		2		N		Y		2BS

- ZA184(I) Touchdown zone
- ZA181(I) Runway centreline



**atg airports ltd**  
 Lowton Business Park | Newton Road  
 Lowton St. Mary's | Warrington  
 WA3 2AP | United Kingdom

**atg airports inc**  
 7857 Drew Circle #11  
 Fort Myers | Florida 33967  
 USA



UK: +44 (0) 1942 68 5555 | USA: 001 (239) 985-9406

www.atgairports.com | products@atgairports.com | sales-usa@atgairports.com

**ZA181** PSA Version