



IR852T

Taxiway and Apron edge
High intensity
lighting solutions

Compliant to Latest International Standards*

- ▶ ICAO Annex 14. Vol 1
- ▶ FAA AC 150/5345-46
- ▶ FAA Engineering Brief No.67
- ▶ IEC 61827
- ▶ EASA
- ▶ Stannag 3316 (NATO)

Applications

CAT II/III all weather operation airfield ground
lighting (agl) systems.

* As applicable to the application, compliance with other civil aviation and
military regulations confirmed on request

† Electrical/Mechanical/Environmental characteristics only

IR852T

LED Inset Taxiway and Apron edge
High intensity lighting solutions



Electrical Performance

Main Beam Aperture		Colour	Typical Power Consumption - Watts (VA) @ 6.6A					
Horiz(°)	Vert(°)		Per Beam Watts nominal	Fitting*		Tx Primary**		
				Watts (VA)	PF	Watts (VA)	PF	
0-359	0-6	Blue	0.75	4.71(4.74)	0.993	12.87(13.01)	0.991	10W
0-359	0-6	Blue	0.75	4.67(4.70)	0.993	13.76(14.09)	0.977	25W
0-359	0-6	Blue	0.75	4.64(4.66)	0.994	16.23(17.16)	0.948	45W

Fixture Operational Current Range: 2.8 to 6.7A RMS

* as measured at the input leads of the fixture.

** as measured across the primary winding of an appropriately sized isolation transformer with a total fixture and transformer secondary length not exceeding - 1.85m (72").

*** electrical characteristics measured with 45 watt transformer, fitting can operate from transformers up to 210 watts.

Note: Isolating transformer shall be suitably sized to accommodate specific secondary and other applicable losses.

Photometry

Specification

Taxiway & Apron Edge omni-directional ICAO - 5.3.18.7/8 FAA L-852T

Colour	Blue
Main rect. minimum intensity 0°-6°	2 cd
Second rect. minimum intensity 6°-90°	0.2 cd

Typical Measured Values

Colour	Blue
Main rect. minimum intensity 0°-6°	3.0 cd
Main rect. minimum intensity 0°-8° (Stannag)	2.9 cd
Second rect. minimum intensity 6°-90°	1.0 cd

Photometry vs. Specification

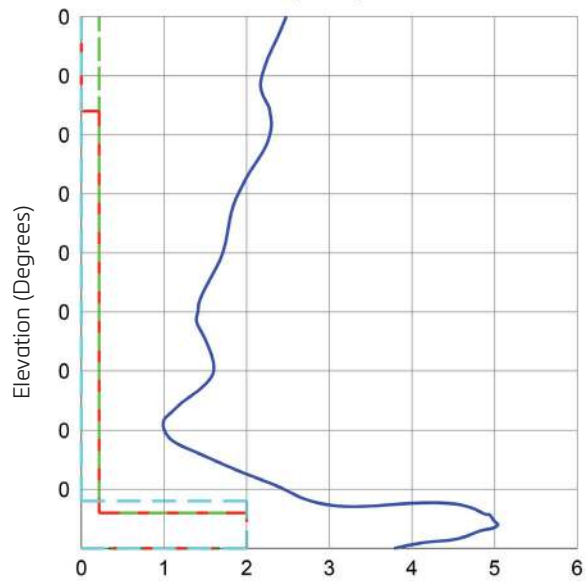

— IR852T(L) Performance @ 6.6A

Specification

- ICAO Annex 14, EASA, CAP 168, FAA-46E, MADS 38(b)
- IEC61827
- Stannag 3316

IR852T

LED Inset Taxiway and Apron edge
High intensity lighting solutions



Features

Low energy consumption compared with the tungsten halogen equivalent.

Greatly reduced maintenance: calculated MTBF of 75,000 hours at 6.6A.

Operates on the full range of 2.8A to 6.6A on either 3 or 5 step IGBT, ferroresonant or thyristor CCRs that are designed in compliance with IEC or FAA requirements.

Fully dimmable lights, replicating the response curve of traditional halogen lights.

Full compatibility with existing airfield lighting series circuits. Installation on same mounting device as most conventional lights, for a straightforward replacement.

Low operating temperature, ensuring longer component life.

L-823 connectors

Integral surge protection

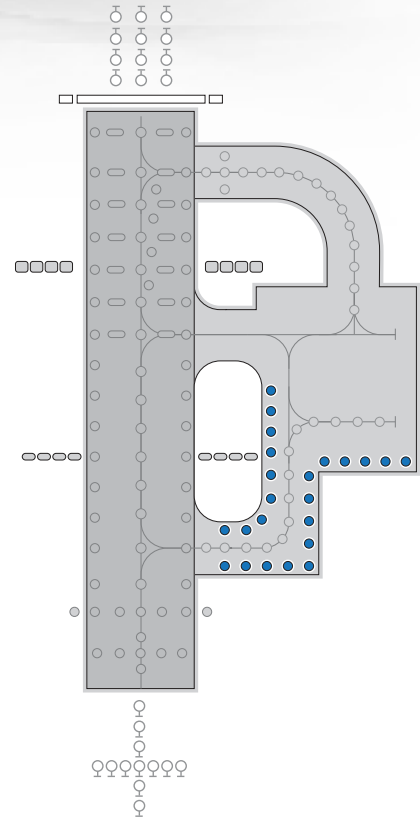

Environmental Conditions

- ▶ Ambient Temperature -55 °C to +55°C (-67 °F to +131°F)
- ▶ Storage Temperature -55°C to +70°C (-67 °F to +158°F)

- ▶ Atmospheric Altitude up to 10,000 feet (3000m)
- ▶ Relative Humidity 0-100% (sealed unit)

Standards	
EMC protection	Immunity IEC 61000-4 Emission IEC 61000-2
Ingress protection class dust/liquids	IP67 (IEC69598-1)
Vibration resistance	IEC60068-2-6

UK: +44 (0) 1942 68 5555 | USA: +1 (239) 985-9406

www.atgairports.com | enquiries@atgairports.com | sales-usa@atgairports.com

L-852T(L)

IR852T

LED Inset Taxiway and Apron edge
High intensity lighting solutions



Ordering Codes:



Application
L-852T(L) Taxiway & Apron Edge
omni-directional

Beam Type
7 = Omni directional (360°)

Colour
B = Blue

Optional Shield
1 = 180° Shield
0 = No Shield

Specification
1 = FAA
2 = ICAO
3 = MOS 139

Beam Options

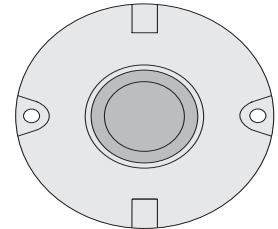

IR852T(L)
Omni Directional 360°

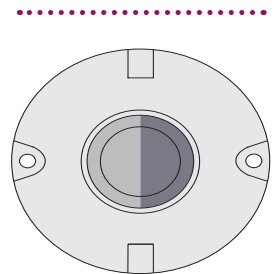

IR852T(L)
Omni Directional with 180° Shield

Additional optional features may be available upon request

IR852T

LED Inset Taxiway and Apron edge
High intensity lighting solutions

Dimensions

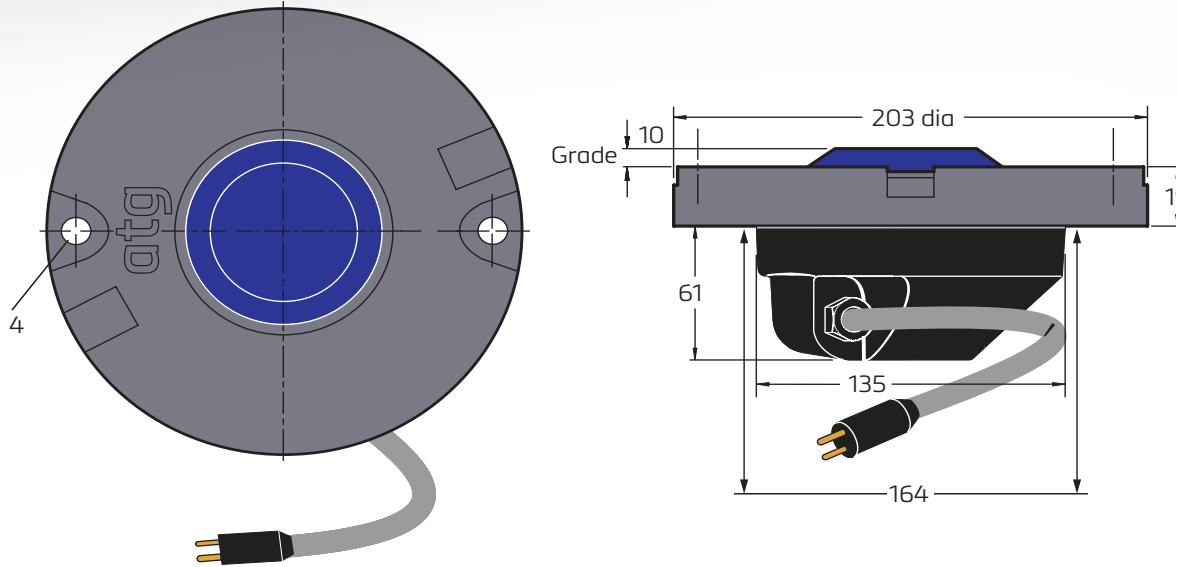

Packaging

▶ Net weight 3kg ▶ Gross weight 3.5kg ▶ Box 230mm(w) x 230mm(d) x 146mm(h)

weights and dimensions are nominal



Head Office:

atg airports ltd

Lowton Business Park | Newton Road

Lowton St. Mary's | Warrington

WA3 2AP | United Kingdom

atg airports reserve the right to change technical data and details at any point in time. Errors may have occurred



UK: +44 (0) 1942 68 5555 | USA: +1 (239) 985-9406

L-852T(L)

www.atgairports.com enquiries@atgairports.com sales-usa@atgairports.com

Rev 4 - 2020