

Tungsten halogen

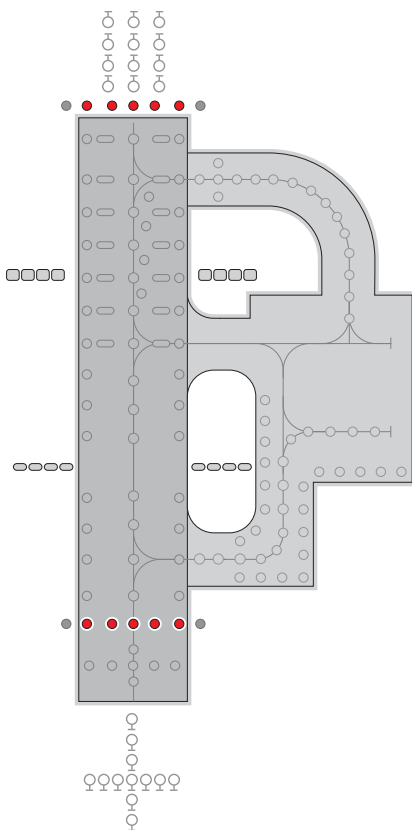

ZA955

Unidirectional runway end medium intensity lighting solutions



Applications

Medium Intensity airfield ground lighting (agl) systems

Compliant with Latest International Standards*

- ▶ CASA MOS Part 139
- ▶ ICAO Annex 14. Vol 1[†]
- ▶ FAA AC 150/5345-46[†]
- ▶ IEC 61827[†]
- ▶ EASA[†]
- ▶ Stannag 3316 (NATO)[†]

* As applicable to the application, compliance with other civil aviation and military regulations confirmed on request

ZA955 Unidirectional runway end medium intensity lighting solutions



Electrical Performance

48 watts lamp, operates from 45 watt series transformer

Fixture Operational Current Range: 2.6 to 6.7A RMS

Notes: Isolating transformer shall be suitably sized to accommodate specific secondary and other applicable losses.

Environmental Conditions

- ▶ Ambient Temperature -55 °C to +55°C (-67 °F to +131°F)
- ▶ Storage Temperature -55 °C to +55°C (-67 °F to +131°F)
- ▶ Ingress Protection IP67

Photometry

Specification

Medium Intensity Runway End MOS Part 139 - Para. 9.65 Fig 9.75(1)

Colour	Red
Max/Min Intensity ratio	<3.0
Main rect. average intensity	50 -300 cds
Main rect. minimum intensity	25 - 100 cds
Second rect. minimum intensity	5.0 cds

Typical Measured Values

Colour	Red
Max/Min Intensity ratio	2.42
Main rect. average intensity	139 cds
Main rect. maximum intensity (A)	189 cds
Main rect. minimum intensity (B)	78 cds
Second rect. minimum intensity	13 cds

Intensity Chart - ZA955 Uni-Directional medium Intensity Runway End

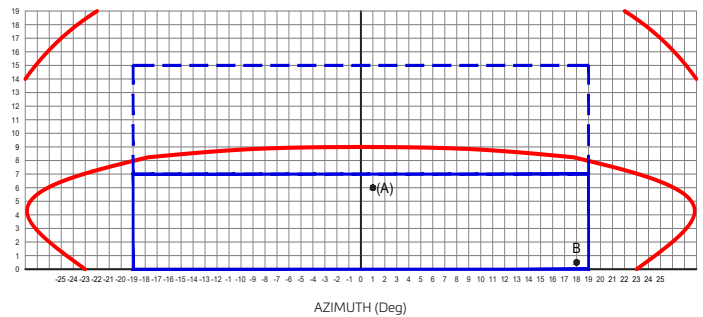

ZA955

Unidirectional runway end
medium intensity lighting solutions



Ordering Codes

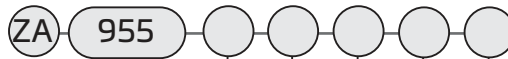

Application
Medium intensity unidirectional
runway end

Beam Type
A Side
5 = Wide
.....
B Side
0 = Blank

Colour
A Side
R = Red
.....
B Side
N = Not Applicable

Specification
3 = MOS139

Beam Options

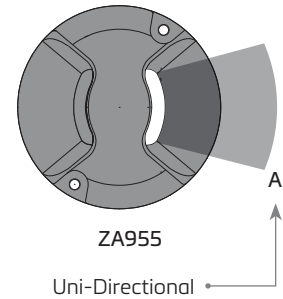

ZA955 Unidirectional runway end medium intensity lighting solutions

Dimensions

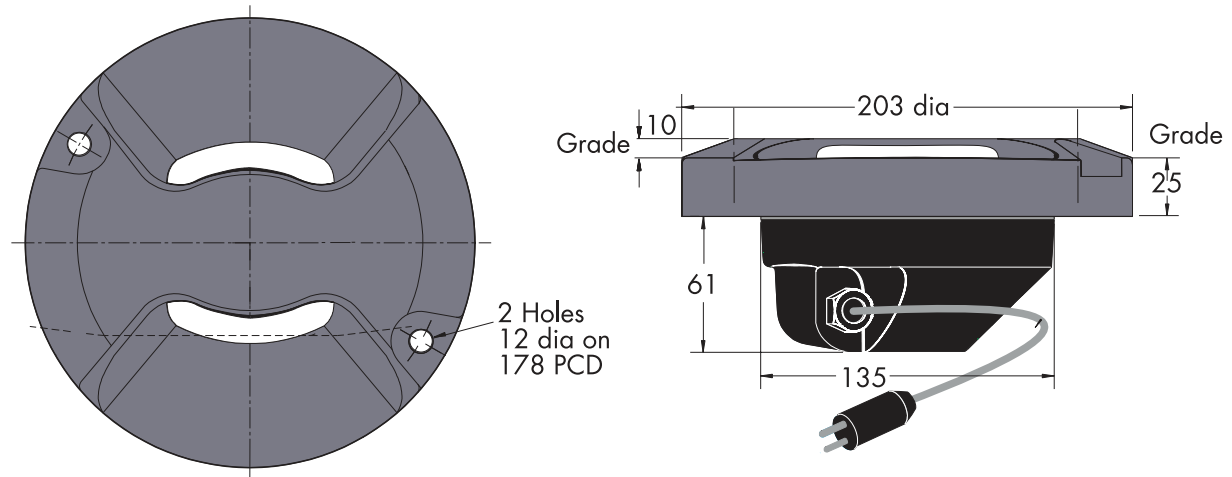

Packaging

▶ Net weight 3.12Kg ▶ Gross weight 3.52Kg (boxed) ▶ Box 260mm (L) x 260mm (W) x 175mm (H)

*Dimensions are nominal



Head Office:
atg airports Ltd
Lowton Business Park | Newton Road
Lowton St. Mary's | Warrington
WA3 2AP | United Kingdom

**THINK
BEFORE YOU
PRINT**



atg airports reserve the right to change technical data and details at any point in time. Errors may have occurred

UK: +44 (0) 1942 68 5555 | USA: 001 (239) 985-9406

www.atgairports.com enquiries@atgairports.com sales-usa@atgairports.com

ZA955