

FX852C

Taxiway centreline
Straight sections
Narrow beam
High intensity
lighting solutions

Compliant to Latest International Standards*

- ▶ ICAO Annex 14. Vol 1
- ▶ FAA AC 150/5345-46
- ▶ FAA Engineering Brief No.67
- ▶ IEC 61827
- ▶ EASA
- ▶ Stannag 3316 (NATO)

Applications

CAT II/III all weather operation airfield ground
lighting systems.

* As applicable to the application, compliance with other civil aviation and
military regulations confirmed on request

† Electrical/Mechanical/Environmental characteristics only

Electrical Performance

Main Beam Aperture		Colour	Typical Power Consumption - Watts (VA) @ 6.6A				
Horiz(°)	Vert(°)		Per Beam Watts nominal	Fitting* Watts (VA) PF	Tx Primary** Watts (VA) PF		
-3.5 to +3.5	1 to 8	GRN/GRN	3.0/3.0	14.60 (14.69) 0.991	23.76 (24.66) 0.965		
-3.5 to +3.5	1 to 8	YEL/YEL	4.5/4.5	15.88 (16.05) 0.992	25.50 (26.34) 0.969		
-3.5 to +3.5	1 to 8	GRN/YEL	3.0/4.5	15.85 (15.94) 0.993	25.30 (26.19) 0.968		
-3.5 to +3.5	1 to 8	GRN/BLK	3.0/----	9.89 (9.92) 0.995	19.15 (19.91) 0.959		
-3.5 to +3.5	1 to 8	YEL/BLK	4.5/----	11.32 (11.54) 0.995	20.65 (21.60) 0.965		

Fixture Operational Current Range: 2.8 to 6.7A RMS

* as measured at the input leads of the fixture.

** as measured across the primary winding of an appropriately sized isolation transformer with a total fixture and transformer secondary length not exceeding - 1.85m (72").

*** electrical characteristics measured with 45 watt transformer, fitting can operate from transformers up to 210 watts.

Note: Isolating transformer shall be suitably sized to accommodate specific secondary and other applicable losses.

Photometry

Specification

Taxiway Centreline - Straight Narrow ICAO Fig A2-13 FAA L-852C

Colour	Green
Max/Min Intensity Ratio	<3.0
Main rect. average intensity	200 cds
Main rect. minimum intensity	100 cds
Second rect. minimum intensity	20 cds

Typical Measured Values

Taxiway Centreline - Straight (Narrow) Green

Colour	Green
Max/Min Intensity Ratio	2.59
Main rect. average intensity	400 cds
Main rect. maximum intensity (A)	512 cds
Main rect. minimum intensity (B)	197 cds
Second rect. minimum intensity	120 cds

Specification

Taxiway Centreline - Straight (Narrow) Yellow

Colour	Yellow
Max/Min Intensity Ratio	<3.0
Main rect. average intensity	200 cds
Main rect. minimum intensity	100 cds
Second rect. minimum intensity	20 cds

Typical Measured Values

Taxiway Centreline - Straight (Narrow) Yellow

Colour	Yellow
Max/Min Intensity Ratio	1.96
Main rect. average intensity	462 cds
Main rect. maximum intensity (A)	584 cds
Main rect. minimum intensity (B)	299 cds
Second rect. minimum intensity	228 cds

Intensity Chart - Taxiway Centreline Luminaire (straight narrow) Green

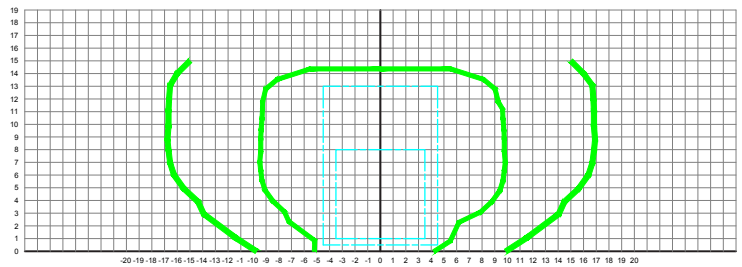

Intensity Chart - Taxiway Centreline Luminaire (straight narrow) Yellow

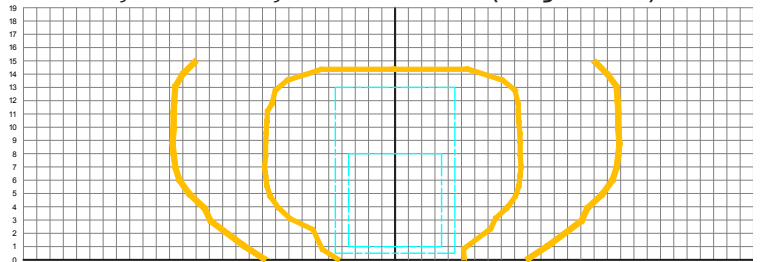

FX852C

LED Inset Taxiway centreline straight (Narrow)
High intensity lighting solutions



Features

- Low energy consumption compared with the tungsten halogen equivalent.
- Greatly reduced maintenance: calculated MTBF of 75,000 hours at 6.6A.
- Operates on the full range of 2.8A to 6.6A on either 3 or 5 step IGBT, ferroresonant or thyristor CCRs that are designed in compliance with IEC or FAA requirements.
- Fully dimmable lights, replicating the response curve of traditional halogen lights.
- Full compatibility with existing airfield lighting series circuits. Installation on same mounting device as most conventional lights, for a straightforward replacement.
- Monitoring function of the individual light arrays for open circuit, short circuit, and over temperature. The LED light automatically disconnects from the secondary side of the isolation transformer, resulting in an open circuit condition.
- Low operating temperature, ensuring longer component life.
- FAA style 3, ICAO style 4 fixture with a 3.5 mm profile above gradient
- L-823 connectors
- Integral surge protection

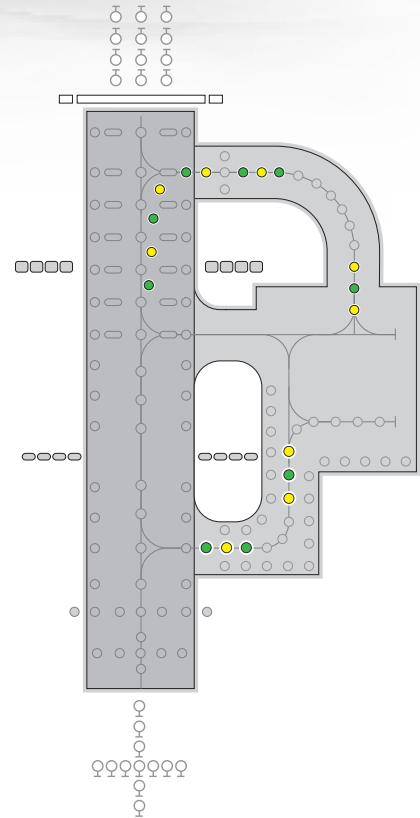

Environmental Conditions

- ▶ Ambient Temperature -55 °C to +55°C (-67 °F to +131°F)
- ▶ Atmospheric Altitude up to 10,000 feet (3000m)
- ▶ Storage Temperature -55°C to +70°C (-67 °F to +158°F)
- ▶ Relative Humidity 0-100% (sealed unit)

Standards	
EMC protection	Immunity IEC 61000-4 Emission IEC 61000-2
Ingress protection class dust/liquids	IP68 (IEC69598-1)
Vibration resistance	IEC60068-2-6

UK: +44 (0) 1942 68 5555 | USA: +1 (239) 985-9406

www.atgairports.com | enquiries@atgairports.com | sales-usa@atgairports.com

L-852C(L)

FX852C

LED Inset Taxiway centreline straight (Narrow)
High intensity lighting solutions



Ordering Codes:



Application
L-852C(L) Taxiway Centreline
Straight (narrow)

Beam Type
A Side
4 = Straight (narrow)
0 = Blank
.....
B Side
4 = Straight (narrow)
0 = Blank

Colour
A Side
G = Green
Y = Yellow
C = Cyan/Green
N = Not applicable
.....
B Side
G = Green
Y = Yellow
C = Cyan/Green
N = Not applicable

Specification
1 = FAA
2 = ICAO

Connections
1 = 1 x Bi-pin plug
2 = 2 x Bi-pin plug

Beam Options

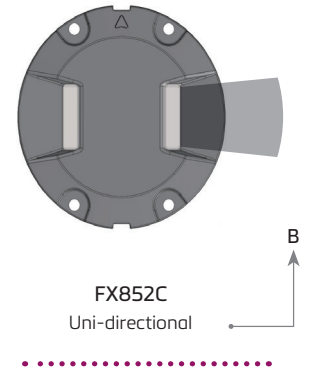
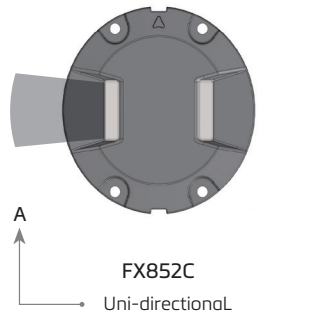
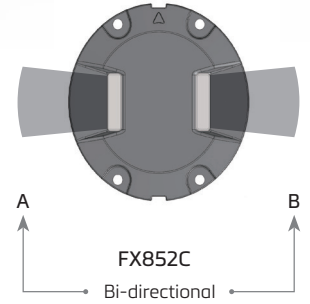

Additional optional features may be available upon request

FX852C

LED Inset Taxiway centreline straight (Narrow)
High intensity lighting solutions

Dimensions

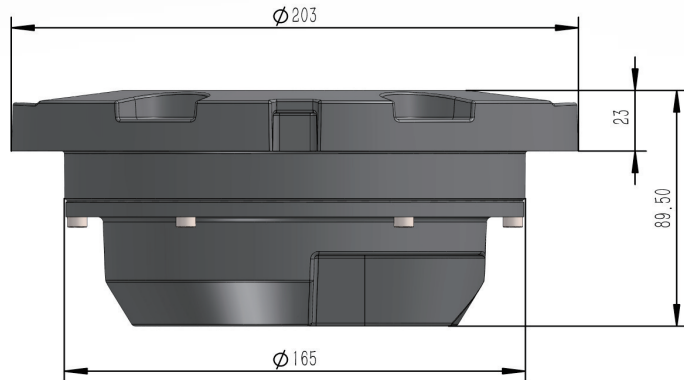
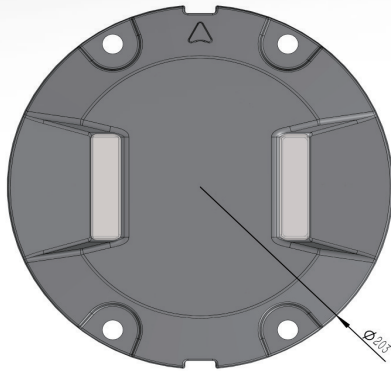

Packaging

- ▶ Net weight 2.5Kg
- ▶ Gross weight 2.9 (boxed)
- ▶ Box 220mm (L) x 220mm (W) x 225mm (H)

weights and dimensions are nominal



Head Office:

atg airports ltd

Lowton Business Park | Newton Road

Lowton St. Mary's | Warrington

WA3 2AP | United Kingdom

atg airports reserve the right to change technical data and details at any point in time. Errors may have occurred



UK: +44 (0) 1942 68 5555 | USA: +1 (239) 985-9406

www.atgairports.com enquiries@atgairports.com sales-usa@atgairports.com

Rev 1 - 2019

L-852C(L)