

Socket Type - Model 90R

Secondary Connector Kits (Model 90R)

Type

Model 90R – 600 volt (or less), nonscreened (unshielded) cable.

Application

To provide separable waterproof connections between **non-screened** primary cable and an isolating transformer.

To make a waterproof separable splice in non-screened primary supply cable.

Description

Each kit contains a plug housing, and a crimp applied plug insert that, when assembled, makes a connector that provides a separable waterproof splice when mated with a model 90P or 91P kit or a 91MR moulded on connector.

Note

As these kits are sensitive to both the outside diameters of the cable and the wire size, please refer to the ordering instructions or alternatively contact [atg airports](http://atgairports.com).



Head Office:

atg airports Ltd

Lowton Business Park | Newton Road

Lowton St. Mary's | Warrington

WA3 2AP | United Kingdom



atg airports reserve the right to change technical data and details at any point in time. Errors may have occurred

UK: +44 (0) 1942 68 5555 | USA: 001 (239) 985-9406

www.atgairports.com | enquiries@atgairports.com | sales-usa@atgairports.com

Model 90R

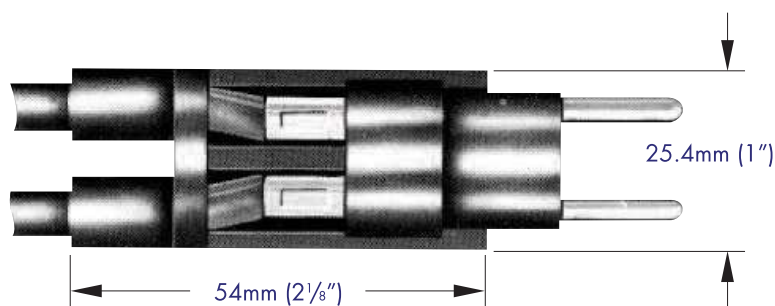

Plug Type - Model 90P

Secondary Connector Kits (Model 90P)

Type

Model 90P – 600 volt (or less), non-screened (unshielded) cable.

Application

To terminate two round waterproof insulated wires with a plug (male) connector conforming to FAA specification L-823, style 4 when field assembling a secondary extension lead, or terminating a fixture lead.

Specification

Conforms to FAA L-823 and Transport Canada K255.

Description

Each kit contains a plug housing, and a crimp applied plug insert that, when assembled, makes a connector that provides a separable waterproof splice when mated with a model 90R or 91R kit or a 95MR moulded on receptacle connector set such as is used to terminate the secondary lead of an airfield lighting transformer.

Note

As these kits are sensitive to both the outside diameters of the cable and the wire size, please refer to the ordering instructions or alternatively contact [atg airports](http://atgairports.com).



Head Office:
atg airports ltd
 Lowton Business Park | Newton Road
 Lowton St. Mary's | Warrington
 WA3 2AP | United Kingdom



atg airports reserve the right to change technical data and details at any point in time. Errors may have occurred

UK: +44 (0) 1942 68 5555 | USA: 001 (239) 985-9406

www.atgairports.com | enquiries@atgairports.com | sales-usa@atgairports.com

Model 90P