



ZA708L

AGNIS Docking Aid Utilising LED

azimuth nose-in guidance lights (agnis)

Application

The ZA708L fitting has been designed for mounting on the face of terminal building piers at approximately pilot's eye height to provide accurate nose-in centreline guidance.

Construction

Constructed throughout of aluminium alloys, the body consists of cast silicon aluminium side frames held rigidly together with tie bars and spacers which also locate the reflector and filter frames.

The front slots are covered by a reeded spreader glass held in adjustable channels. A removable top cover, retained by toggle clips, gives access for cleaning or adjustment of the front frame. Lamp changing and wiring, on initial installation, is through cast aluminium gasketed side covers.

The lamp is fitted to specially designed lampholders arranged to keep the pinch temperature of the lamp to a minimum. Internal wiring between the lampholders and the terminal block is by means of heat resistant wire. Cable entry is through a compression type gland.

The unit is arranged for mounting on a rigid angle iron frame and, for this purpose, four rigid slotted lugs are cast integral with the side frames.

Adequate ventilation is provided for use with the lamp specified. The unit is weatherproofed and designed so that driving rain or snow cannot come into contact with the lamp or other live electrical parts.

Optical system

The optical system consists of high brightness LED's with collimating optics, providing more than 80,000 hours life. The unit is glazed with three vertical strip filters, red in the centre and green on either side. Only controlled light is permitted to emerge from the fitting.

Light emerges from the unit through two slots placed in front of the filters through the spreader glass mentioned above. The 'on-course' indication takes the form of a nominal green signal from both slots. When off-course, one slot appears red and the other green.

The sensitivity of the unit is controlled:

- a) by the width of glazing bars between the filters,
- b) the width and/or spacing of the slots,
- c) their distance from the filters.

The units are normally set so that an observer 30m from the unit will see an off-course signal if he is more than ± 175 mm from the centreline on which the unit is mounted.

Finish

All aluminium parts are treated with zinc chromate primer and finished with matt black paint. The reflector is electro brightened and anodised.

Screws and bolts other than stainless steel will be mild steel, passivated and plated. All paint used is suitable for the temperatures encountered in normal operation.

Operating conditions

The units are designed to operate continuously in ambient conditions ranging from -25°C to +50°C when exposed to sun, rain, snow and wind.

Control gear

Tapped transformers can be provided as an extra, for dimming if required.

Weight

14kg (30lb).

Spares

Lampholder	SLC15001
Clear glass spreader	SLC16028
Red filter glass	SLC19065
Green filter glass	SLC19027
Reflector	SLC28018
Access door gasket	SLC33038

Light distribution

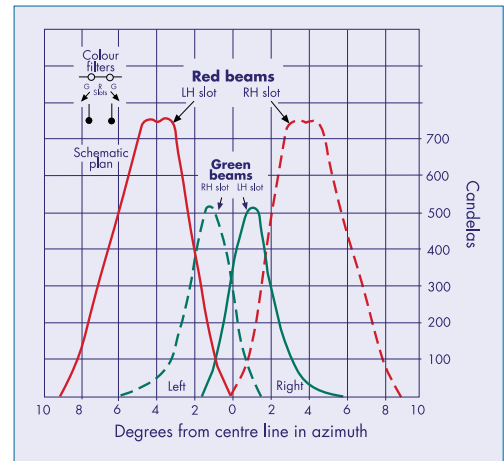

Light distribution in horizontal plane from ZA708 AGNIS indicator with 30W LED.

Dimensions

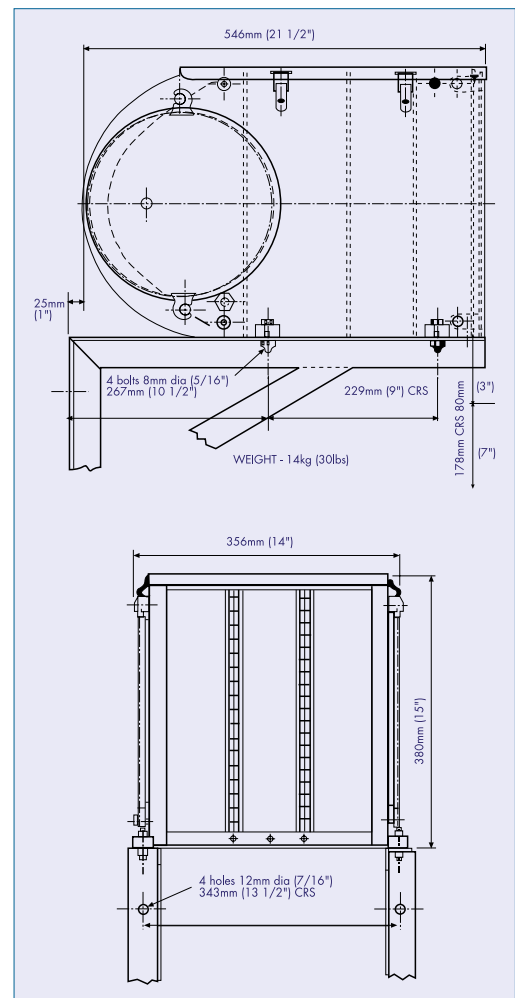

atg airports ltd
 Lowton Business Park | Newton Road
 Lowton St. Mary's | Warrington
 WA3 2AP | United Kingdom

atg airports inc
 7857 Drew Circle #11
 Fort Myers | Florida 33967
 USA



UK: +44 (0) 1942 68 5555 | USA: 001 (239) 985-9406

www.atgairports.com | products@atgairports.com | sales-usa@atgairports.com

ZA708L