

Tungsten halogen technology



ZA486

Threshold Wingbar

High intensity unidirectional inset fitting

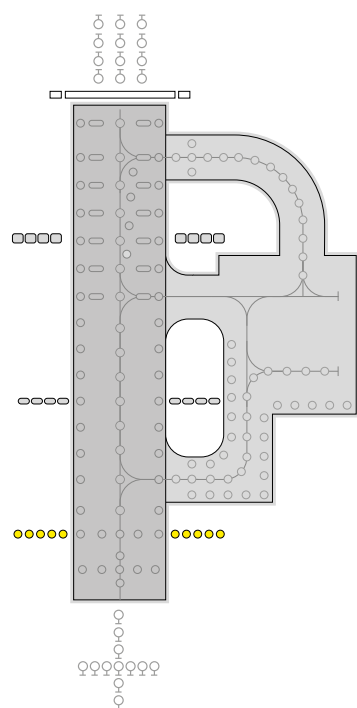

Features

- ▶ Lightweight and robust due to its aluminium alloy construction
- ▶ Components that are common with ZA181 and ZA280 series
- ▶ Long life halogen lamps with a life of 1500 hours at full intensity or over 3500 hours in normal usage
- ▶ Standard adaptor rings to suit 15", 15.5" bases
- ▶ Prism removal and replacement achieved without the need for adhesive or sealants
- ▶ Colour beam variations achieved by dichroic coating
- ▶ Lamp bypass options available when required
- ▶ Pre-focused optics to simplify maintenance procedures
- ▶ Light channel within 5mm of grade
- ▶ Plug for pressure testing
- ▶ Low temperature - temperature at centre of top cover remains below 160°C ICAO and FAA limit
- ▶ All fasteners are stainless steel
- ▶ IMM available on request

Compliance with standards

ICAO	Annex 14
FAA	L-850A,B,C, D, E Class I & IIB, AC150/5345-46C
NATO	STANAG 3316
CAA	CAP168 Figs 6A/1,6A/2, 6A/3, 6A/4, 6A/5 6A/6, 6A/7, 6A/8, 6A/9, 6A/10

Application

High intensity, inset threshold wingbar fitting suitable for use in category I, II and III all weather operation airfield lighting systems.

Options

- ▶ ZM480 seating pot (wet)
- ▶ ZM480 seating pot (dry)
- ▶ PSA & FAA adaptors
- ▶ ZS023 sighting device
- ▶ ZM500/4 lifting handle
- ▶ ZM480 installation jig

UK: +44 (0) 1942 68 5555 | USA: 001 (239) 985-9406

www.atgairports.com | products@atgairports.com | sales-usa@atgairports.com

ZA486

Electrical supply

Suitable for use in 6.6A airfield lighting circuits normally supplied from 100W, 200W or 300W isolating transformers.

Packaging data

Net weight	9.3kg
Gross weight	10kg
Carton size	50mm(w) x 330mm(d) x 330mm(h)

Components

1	Body casting uni-directional (golden yellow) or bi-directional	Not Saleable Not Saleable
2	Clear prism or green prism or blank for prism aperture	SLC16069 SLC19154 SLC40092
3	Prism gasket	SLC33075
4	Prism clamp	SLC32037
5	Prism clamp gasket	SLC33069
6	Bottom cover gasket	SLC33076
7	Bottom cover casting (single lead) or bottom cover casting (twin lead) or bottom cover casting (three lead)	Not Saleable Not Saleable SLC40114
8	'B' type plug lead	SLC13026
9	Cable gland assembly	SLC21282/3/4
10	Cable clamp	SLC21281
11	Reflector lamp 105W	SLC08075
12	Lampholder	SLC32040
13	Lamp retaining spring	SLC32039
14	Lamp gasket	SLC33077
15	Mounting plates: Approach, Siderow and Wingbar Threshold (axial), runway end Threshold (LHT), runway end Threshold (RHT), runway end	SLC21278 SLC21279 SLC21287 SLC21286
16	Lampholder support block	SLC21285
17	Pressure test plug	SLC21256

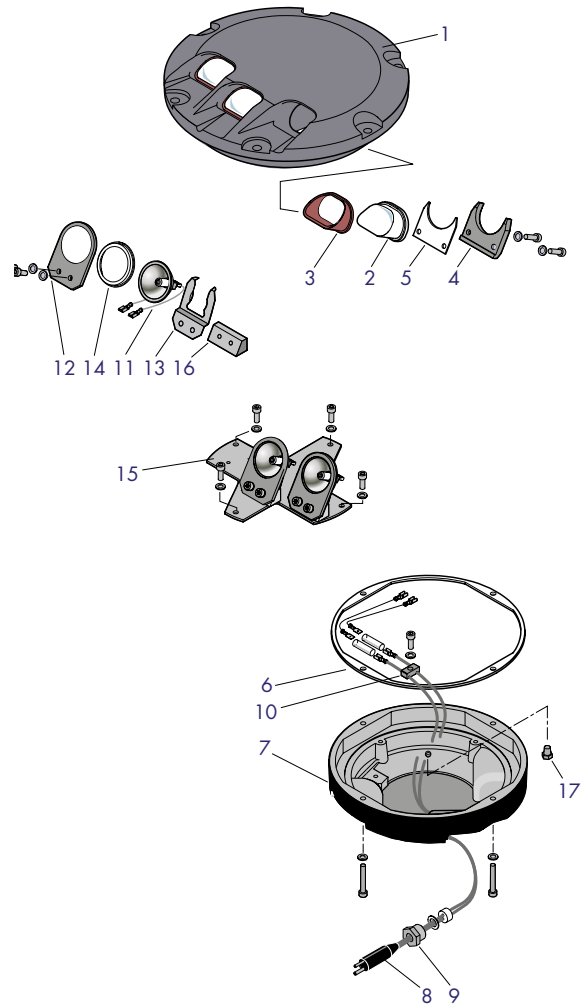

Typical installation methods

- In a 12" dia seating pot, atg airports ltd type ZM480

ZA486 Installed in ZM480 Seating Pot (dry version)

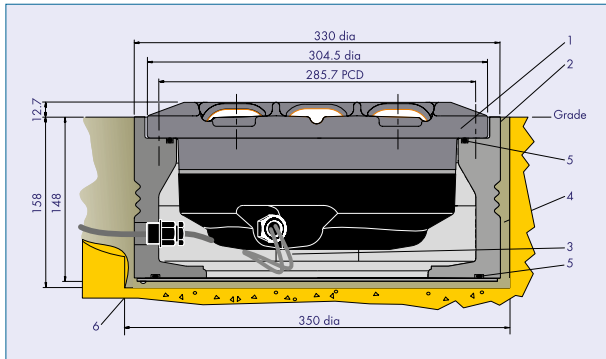

- | | |
|-------------------------|----------------|
| 1. ZA486 Fitting | 4. Grout |
| 2. ZM480 Seating Pot | 5. 'O' Ring |
| 3. Secondary Connection | 6. Cable Gland |

Note ZM480 Wet seating pot arrangement information available on request.

- In a 12" FAA L-868 Base

ZA486 Installed on FAA L-868 Base

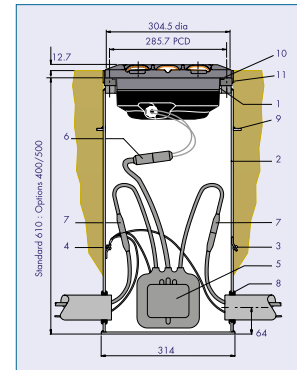

- | | |
|------------------------------------|-----------------------|
| 1. ZA486 Fitting | 7. Primary connection |
| 2. FAA L-868 Base (one piece) | 8. Grommet |
| 3. Outer earth terminal (optional) | 9. Anchor ring |
| 4. Inner earth terminal (optional) | 10. 'O' Ring |
| 5. Isolating transformer | 11. Dam ring |
| 6. Secondary connection | |

Photometric performance

Threshold Wingbar Inset Fitting:

Green	ZA486	Nominal Lamp Details	
Main Ellipse Intensity Measurements (Candelas)		Power	3 x 105 Watts
Average	11409	Current	6.6 Amps
Min. Average	10000	Type	Cold Reflector Lamp
Max (B)	13990	ICAO	CAP168
Min (A)	7622	Annex 14	FIG 6A/4
			FIG 2.4

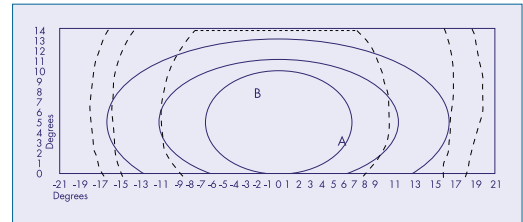

atg airports ltd
 Lowton Business Park | Newton Road
 Lowton St. Mary's | Warrington
 WA3 2AP | United Kingdom

atg airports inc
 7857 Drew Circle #11
 Fort Myers | Florida 33967
 USA



UK: +44 (0) 1942 68 5555 | USA: 001 (239) 985-9406

www.atgairports.com | products@atgairports.com | sales-usa@atgairports.com

ZA486